

ROBOTIC ARM CONTROL USING FUSION BAND AND HAND GESTURE RECOGNITION

Gaurav S. Sawarkar

Department of Communication Engineering YCC, Enagpur,(India)

ABSTRACT

Robots make our life easier. Engineering are up to the challenge, and over the past few years they have developed robotic hands with unprecedented strength and sensitivity. Sensor plays an important role in robotics. Robotic application demand sensors with high degrees of repeatability, precision, and reliability. The pick and place operation of the robotic arm can be efficiently controlled using fusion band. This design work is an educational based concept as robotic control is an exciting and high challenge research work in recent years. [1]Our robotic hand controlled wirelessly with fusion band works in synchronization with human hand and has precise and accurate movements with increased range.

Keywords: *Accelerometer, CC2500 Wireless Module*

I. INTRODUCTION

Robotic tele-operation indicates the remote manipulation of a robot by human operator at a distance. In some specific situation where human can't work directly, robots are used. For most people it is incredibly easy to move their arm. This nature ability can be exploited to give a human operator an easy to use interface to control a robot.

In this project, two sensor fusion input armband devices with the ability to be used by any individual with some level of arm movement and arm voluntary muscle contraction control will be used. The user hand motion will provide a natural and effective way to precisely manipulate the robot with very little training. The devices which will be used are GE-Fusion (Gyro and EMG fusion) and MEA-fusion (Magnetometer, EMG and Accelerometer) Bands, both combined into a small box.

[2]Hand gesture recognition provides an intelligent, natural and convenient way of human computer interaction. Sign language recognition (SLR) and gesture-based control are two major applications for hand gesture recognition technologies. There are two technique used, such as

1.1 Vision Base Gesture Recognition

In vision base gesture recognition, according to technology, computer visions capture the gesture of human hand and display to computer human perform in that time. This technology basically in the field of service robotic there are two gesture recognition methods first is the Temple base approach and natural base approach this is compared and combined with Viterbi algorithm for the recognition of gesture

1.2 Motion Capture Sensor Recognition

In motion capture sensor recognition, Accelerometer sensor used to sense the motion of human hand and creates three dimensional analog output voltages. Today accelerometer is small surface mount component. There are three axes X, Y, Z which is labeled in it. And flex sensor is used to control the wrist movement of hand.

II FUSION BAND

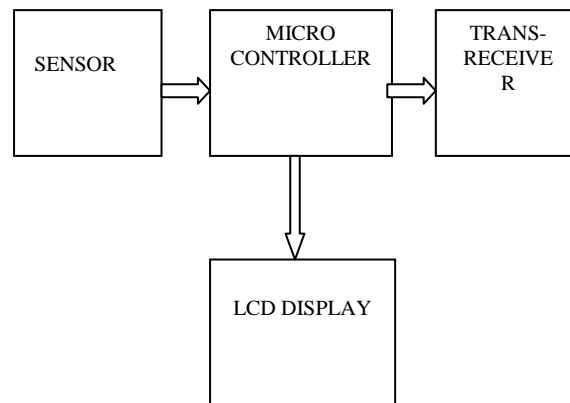

Fig. Block Diagram of Fusion Band

2.1 Sensor



Fig. Accelerometer

EMG (Electromyography) sensor is muscle sensor to enhance control. It is measure very small electrical potential produce during muscle activation. Accelerometer is used to measure the rotation of human body and Magnetometer used to measured angle of body.

2.2 Microcontroller

ATmega16 microcontroller used as the hardware platform. It is controlling unit which all component such as Accelerometer, wireless module, servo motors are interface.

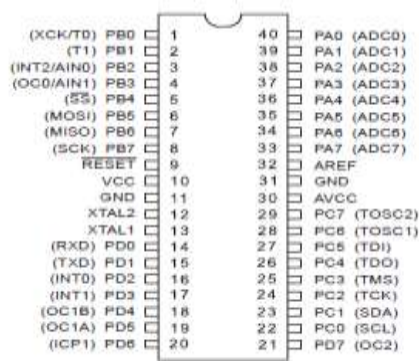

Fig. PIN diagram of ATmega16

2.3 CCC2500 Transceiver Module

This module can be used for multi way wireless data transmission. It is small size and best range. In this module Up to 250 devices can communicate each other. It work at voltage 4.5 to 5.5Volts and operating range is 30 meter



Fig. CC2500 module

III DISSCUSSION ABOUT FUSION BAND

The device are called GE-Fusion (Gyro and EMG Fusion) and MEA-Fusion (Magnetometer, EMG and Accelerometer)

Bands both are combined into a small box[1]. However by combining sensor, such as combing Accelerometer and EMG sensor for sign language. Combining the Accelerometer and Gyro for motion analysis.

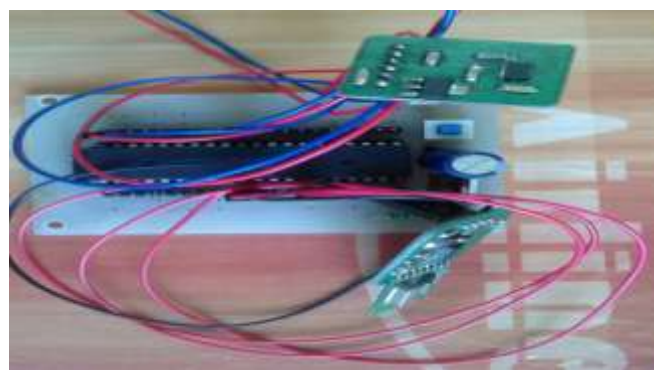

Fig.1

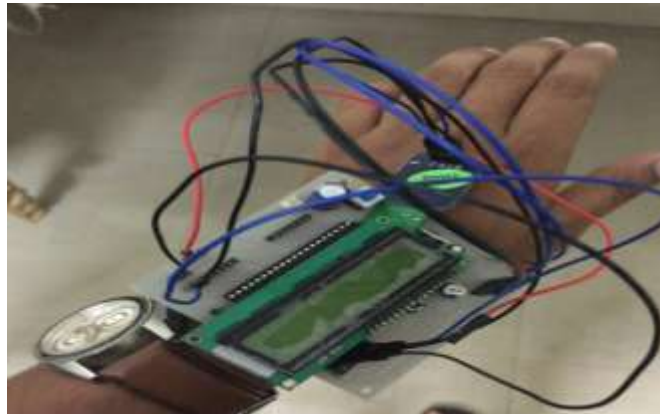

Fig.2

Fig. 1 & 2 fusion band

Yaw and Pitch motion was chosen for control purpose as shown in figure. The robotic arm can be rotate 180 degree of Yaw. To use the Fusion Band a portion of the arm must be movable in yaw (left/right) and pitch (up/down) direction as shown in figure. Fusion Band completely change the way we interacts with industrial machines and robots[1].



Fig. Fusion Band Freedom of Motion [Cut C IEEE 2012]

3.1 Robotic Arm

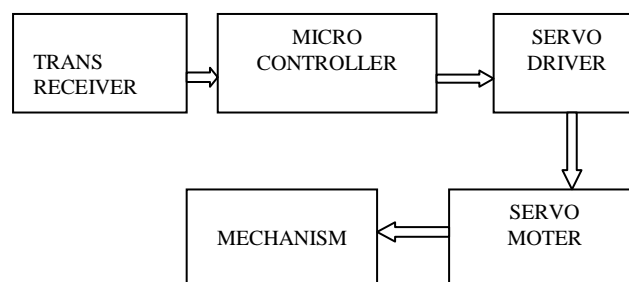

Fig. Block diagram of Receiver part of Robotic Arm

A robotic arm is a type of mechanical arm, usually programmable with similar function to a human arm. Most Robots in the world are design for heavy, repetitive manufacturing work. This task is difficult to handle or boring to human beings. The most manufacturing robot is robotic arm. The robot uses motion sensor to make sure it move just the right amount.

3.3 Servo Motor



Fig. Servo motor

Servo motor are used to control the finger movements and wrist movements of the hand. The Rc Servo motor usually have rotation limit from 90 to 180 degree. Servo motor do not rotate continually.

IV EXPECTED OUTCOME

A wireless robotic hand that will be designed to work in synchronization with human hand with precise and accurate movement will also employ a gesture base technique for effective control.

V CONCLUSION AND FUTURE WORK

In this paper, fusion band consists of magnetometer, accelerometer for motion control. Fusion band interface with human hand and capture the motion of human hand. The Fusion band are ideally suited to work with small devices.

In Future research, it include additional feature such as voice recognition to interaction. In future it will be work more range than this paper.

REFERENCE

- [1] James Cannan, Huosheng Hu. "A Multi-Sensor Armband based on Muscle and Motion Measurements" IEEE International Conference on Robotics and Biomimetics. [2012]
- [2] Wang Wen-hui Yang Ji-hai Vuokko Lantz-Wang Kong-qiao Zhang Xu, Chen Xiang "A Framework for Hand Gesture Recognition".[2011]
- [3] Kostas J. Kyriakopoulos Panagiotis K. Artemiadis "Estimating arm motion and force using emg signals: On the control of exoskeletons" IEEE International Conference on Intelligent Robots and Systems [2008]
- [4] Xiang Zhang Weidong Geng Xiubo Liang, Shun Zhang. "Motion based perceptual user interface. [2009]

- [5] Rene Winkler Johannes Schumm Martin Kusserow Holger Harms,” Oliver Amft and Gerhard Troester. Ethos: Miniature orientation sensor For wearable human motion analysis” [2010]
- [6] Wang Wen-hui Yang Ji-hai Vuokko Lantz-Wang Kong-qiao Zhang Xu, Chen Xiang. “Hand gesture recognition and virtual game control based on 3d accelerometer and emg sensors” IEEE transaction on system [2009]
- [7] Nikhil Kadam, Siddhesh Gaiki, Nupur Tupkar, Sakshi Hiwanj. Wirelessly Controlled Robotic Hand [2013]