



IMPLEMENTATION AND ANALYSIS OF MICROCONTROLLER BASED SOFT STARTER FOR THREE PHASE INDUCTION MOTOR

Miss. Ashwini A. Parit¹, Dr. Prof. B. T. Salokhe²,

Miss. Supriya S. Patil^{#3}

*^{1,3}Student of M.E., ²Associate Prof., Electronics Department, T.K.I.E.T.Warananagar,
Shivaji University, Kolhapur, (India)*

ABSTRACT

This paper presents implementation and analysis of microcontroller based soft starter for three phase induction motors. It is system consisting of IGBT's at inverter in the driving circuit. Three phase induction motor of ratings beyond 50kW take very large currents and low power factor while being started directly from a three phase supply. In order to mitigate the adverse effects of starting torque transients and high inrush currents in induction motors, a popular method is to use electronically controlled soft starting voltages using IGBT's. The soft starter is connected in motor drive during the starting condition only and once the motor gets its rated speed driving circuit works in its normal operation.

***Index Terms:** IGBT, Three phase induction motor, soft starter.*

I.INTRODUCTION

Three phase induction motors are considered work horses of industry converting up to 80% of all electrical power into mechanical energy and cover up many industrial applications such as fans, blowers, mixers, conveyors etc [1]. These are used in wide range of operating areas as they have simple and robust structure and low production costs. Three phase induction motors are accountable for 85% of capacity of industrial driving systems. An induction motor draws a high starting current and develops a high torque during start-up. The high starting current often causes problem such as voltage dips which will be penalized by the energy companies [2]. Therefore protection of these motors is necessary for reliable operation of loads. Three phase induction motor produces severe starting torque pulsations. This causes shocks to the driven equipment and damage to the mechanical system components. By using soft starters we can limit the inrush current at the starting of induction motors so that it will have a smooth start and also torque will be reduced. It will avoid the damage to machine parts. The soft starter certainly becomes a kind of improving the necessary depth ac motor application equipment [3]. One method for soft starters is to use three floating capacitor H-bridge converters can be used to control

the motor voltage during starting and hence limit the motor starting current to the desired level [4]. Another strategy is to use wye-delta soft start method of the three-phase induction motors and its control device based on SCR switches [5]. Use of IGBT for the starters can lead us to protection of system.

II. PROPOSED METHODOLOGY

2.1. Methodology

The implementation diagram consists of three main blocks. Three phase induction motor, driving circuit, soft start circuit. This project takes an attempt to develop a starting system for three phase induction motors such that system will undergo high starting current of the induction motor. Here we will be using IGBTs as the soft starters for three phase induction motors because of their higher power rating and high efficiency.

2.2. Objective

- ❖ To control the starting characteristics of induction motor to match the requirement of application:-These starters have the ability to control the starting characteristics of induction motor to match the application requirements such as acceleration deceleration time, starting and overload current and motor torque. In addition these provide protection against number of potential damaging circumstances.
- ❖ To limit the inrush current that a motor draws from the utility at starting:-When induction motor is started at starting period it draws a very high current from utility. This is a concern because a large starting current may cause the line voltage to dip impacting other loads that are sensitive to low voltages. This may cause damage to motor.
- ❖ To provide protection for the motor against supply fluctuations:- When there are supply fluctuations the system will provide protection against those fluctuations like over voltage, over current and load fluctuations.
- ❖ To reduce stress on machine parts and mechanical arrangement:-When the large inrush current occurs there significant magnetic forces are created in the motor windings. These cause some parts of windings to be attracted to each other and to other parts repulsed. This mechanical shock can damage the winding insulation leading to early failure. The mechanical shock of high torques produced with a large starting current can cause failure of system elements such as motor shaft, belting, gear box, and drive train and damage to fragile contacts.

III. BLOCK DIAGRAM

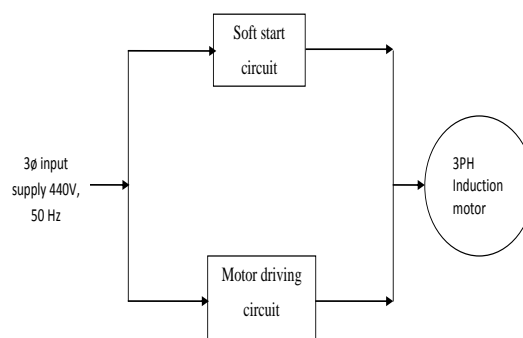

Fig1: System block diagram

1. As shown in Fig1 3 ϕ induction motor is connected to driving circuit as well as soft starter circuit. Initially soft starter circuit is in consideration till motor acquire rated speed. Once motor is operating at rated speed it continues its normal operation and it is driven by driving circuit only. By using soft starter the control voltage is applied at the motor input so the motor is protected and its life increases.

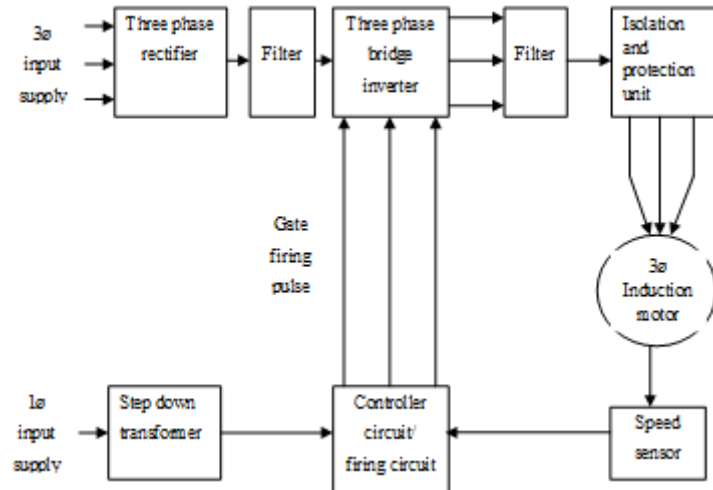

Fig 2: Block diagram of driving circuit

2. Fig2 shows the block diagram of driving circuit. Driving circuit consists of rectifier, inverter, controller and filter units.

- ❖ The power circuit consists of diode bridge rectifier, IGBT based induction motor soft starter with three phase AC supply, capacitor filter and PWM voltage fed inverter. Three phase bridge rectifier is made up of 6 diodes. It is connected to capacitor filter and then to inverter.
- ❖ In the inverter IGBT's are used as switches. To operate the switches the gate pulses should be given. The control circuit will give the required gate pulses for inverter switches. In this work an attempt is made to develop a soft starter for a three phase Induction Motor drive. The soft starter uses two anti parallel connected switches in each phase. The IGBT's are used as the switches in this work because of their higher power rating and high efficiency.
- ❖ Firing angle will be controlled by using controller circuit which is firing circuit of that inverter. It is programmed to vary the frequency of six gate pulses.
- ❖ Isolation and protection unit is provided in order to remove any fluctuations in the supply and hence prevent motor from damage. Protection will be provided in accordance with the controller circuit.
- ❖ The output of inverter will be a square wave so it will contain harmonics. Hence in order to reduce harmonics we are going to employ a filter circuit which is nothing but a passive filter which will be reducing the harmonics.

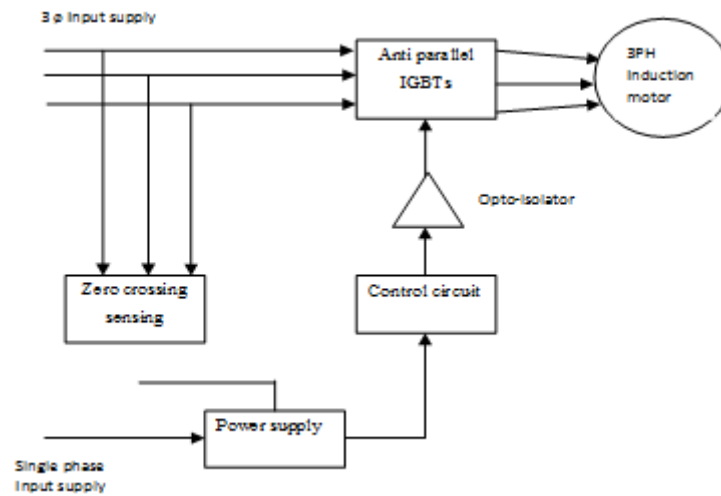

Fig 3: Block diagram of soft starter circuit

3. Fig.3 shows the block diagram of a soft starter circuit. In the soft starter again the IGBTs are used as the switches. It consists of zero crossing sensing, control circuit and soft starter (anti -parallel IGBTs).

- ❖ The zero crossing is used to know where exactly the input voltage is crossing the zero point, depending upon the zero crossing of the input voltage the particular switch of the starter circuit is turned on. By controlling the gate pulses of the switches we are giving the controlled voltage at the motor input terminals.
- ❖ Soft starter is made of anti-parallel IGBTs. Opto-isolator unit is provided for IGBT protection. It will provide isolation for IGBTs.
- ❖ Control circuit is used for controlling the firing angle of IGBTs as stated earlier.
- ❖ Here the power supply is given for each switch independently in soft starter. Also it is given to zero crossing sensor and control circuit. The same supply of zero crossing is also used for speed sensor.

IV. CONCLUSION

In this paper a new system is proposed for soft starting of three phase induction motor. Here we expressed use of IGBT's as the electronic switches for soft starter. IGBT's provide the high efficiency. The system concerns about the safety of three phase induction motor. IGBT's provide much safety to the system as well as isolation and protection unit controls the other factors.

V. ACKNOWLEDGMENT

I would like to express my sincere thanks to my guide Prof.B.T.Salokhe for his motivation and useful suggestions which truly helped me in improving the quality of this paper. I take this opportunity to express my thanks to my teacher, family and friends for their encouragement and support.

REFERENCES

- [1] Hamdy. A. Ashour, Raina. A. Ibrahim, "Implementation and analysis of microcontroller based soft starters for three phase induction motors"EUROCON, 2007. The International Conference on; Computer as a Tool; Date of Conference:9-12 Sept. 2007,1-4244-0813-X/07/2007 IEEE.pp.2193 - 2199.
- [2] Pillay, K. ,Nour, M. , Yang, K.H. , Harun, D.N.D. ,Haw, L.K. "Assessment and comparison of conventional motor starters and modern power electronic drives for induction motor starting characteristics" Industrial Electronics & Applications, 2009. ISIEA 2009. IEEE Symposium on (Volume:2) :4-6 Oct. 2009.10.1109/ISIEA.2009.5356387IEEE. pp.584 - 589.
- [3] Li Shue, Fu Chao "Design and Simulation of Three-phase AC Motor Soft-start" Intelligent System Design and Engineering Applications (ISDEA), 2013 Third International Conference:16-18 Jan. 2013.10.1109/ISDEA.2012.135. IEEE.pp.554 – 557.
- [4] Leng, S.,Ul Haque, R. ,Perera, N. ,Knight, A. ,Salmon, J. "Soft start of induction motors using floating capacitor H-bridge converters" Power Electronics, Machines and Drives (PEMD 2014), 7th IET International Conference: 8-10 April 201410.1049/cp.2014.0341. IET. pp. 1 to 6.
- [5] Zhang Zili, Cui Xueshen , Zhao Haisen , Yang Yaping. "Research on a novel wye-delta soft start method of three-phase induction motor" Power Electronics and Motion Control Conference (IPEMC), 2012 7th International (Volume:4) 2-5 June 2012.10.1109/IPEMC.2012.6259246. IEEE. pp. 2479– 2483.