

# Classification of Faults on Distribution Network with D-STATCOM using Fuzzy Logic Technique

R. Jayant Kumar<sup>1</sup>, Lavleen Kaur<sup>2</sup>, Mr. R. Jayant Kumar<sup>3</sup>

<sup>1</sup>M.Tech Scholar, Department of E.E.E, RSR-RCET, Bhilai, Chhattisgarh (India)

<sup>2</sup>Assistant Professor, Department of E.E.E, RSR-RCET, Bhilai, Chhattisgarh (India)

<sup>3</sup>M.Tech Student, Electrical and Electronics Engineering Department, RSR-RCET, Bhilai, C.G (India)

## ABSTRACT

*This study presents easy and efficient method of fault classification on distribution networks with distribution static synchronous compensator (D-STATCOM) using fuzzy logic. When fault occurs in the system current waveforms are distorted due to transients and their pattern changes according to the type of fault in the system. Samples of post fault currents from all three phases and samples of zero sequence and positive sequence current at one end of the distribution network are being used to classify the nature of the faults. To illustrate the effectiveness of the proposed technique extensive simulation studies, using MATLAB, have been carried out for different types of fault considering wide variations in the operating conditions. The simulation studies of the proposed method indicate that the accuracy in fault classification is high hence the proposed technique is capable of right tripping action.*

**Keywords:** *Distributed network, D-STATCOM, Fault, Fuzzy logic, Fault classification*

## I. INTRODUCTION

The performance of a power system is greatly affected by faults on transmission and distribution lines, which results in the interruption of power flow. The quick detection of faults and accurate classification of faults helps in faster maintenance and restoration of supply resulting in improved economy and reliability of the power supply. The introduction of power electronics in transmission and distribution networks has increased significantly over the last two decades. Some examples of these new developments are the extensive use of power converters and Flexible AC Transmission Systems (FACTS) to enhance the power transfer capability and stability of the power.

These developments also represent some new challenges to other electrical engineering areas. For example, in power system protection is one of great interest to assess the impact that dynamic compensators may have on conventional protection schemes. This is because FACTS controllers, like the Thyristor Controlled Series Compensator (TCSC), can modify the impedance measured by conventional distance relays [1-2]. This is also true for the case of Static Compensators (STATCOM); for example, in [3-4] the authors have demonstrated that these devices have an impact in the tripping characteristic of protective relays. On the other hand, the authors in [5-6] have demonstrated that the SSSC also affects the tripping characteristics of distance relays. From the above point of view, power electronic devices can have an impact in the characteristics of modern protection schemes.

The development of new protection schemes for power transmission and distribution networks with power electronic devices in service is a need. In [7], the authors have proposed a method for protecting power transmission lines with a SSSC in service. In this, the protection approach is based on compensating the zero sequence voltage injected by the SSSC. In [8] the authors have presented fault detection, classification and section identification on distribution network with D-STATCOM using artificial neural network (ANN). This method required extra effort to obtain training of ANN. In general, the fault detection and classification in distribution networks with a STATCOM device in service is a great challenge, because this device injects voltage and current to the distribution network which may lead to over-reach in conventional distance relay and therefore malfunctioning. To overcome these difficulties, new alternative techniques are being continuously explored.

This paper describes the use of fuzzy logic technique to distinctly identify the nature of fault on distribution network with D-STATCOM. Samples of three phase post fault current, zero sequence and positive sequence current are being considered for the fault classification. Extensive simulations have been performed considering a wide variety of conditions to satisfy the validity of the proposed method. The generated fault data from the simulations has been used to feed the “Fuzzy logic toolbox” of MATLAB.

## II. FAULT CLASSIFICATION METHODOLOGY

The fault classification technique adopted for the study is applied on simulation model shown in Fig. 1.

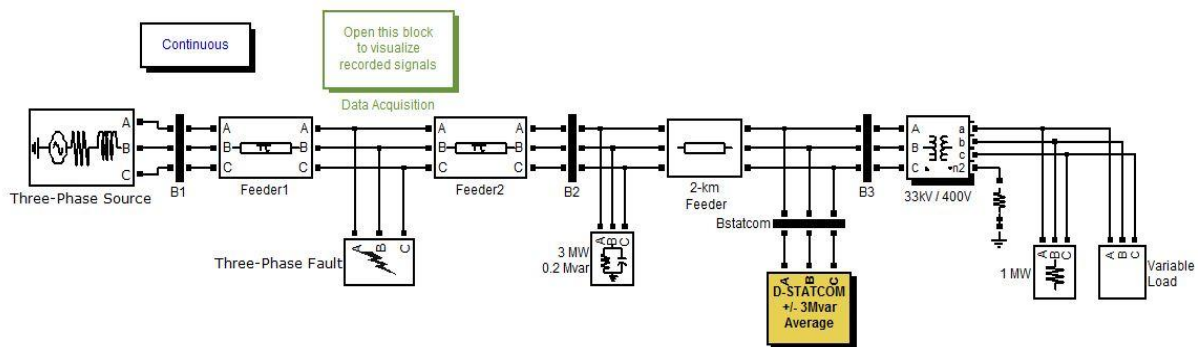

**Figure 1: Simulink model of distribution network with D-STATCOM**

In this model the D-STATCOM is used to regulate the parameters of 33kV, 50 Hz distributed network. We consider here, a +3/-3Mvar D-STATCOM connected to distribution network. Two feeders of 21 km and 2 km are there which transmit power to the load. Feeder of 21 km is modeled by pi-equivalent circuit and connected between the bus 1 and bus 2, whereas 2 km feeder is connected between bus 2 and bus 3. For power factor correction, a shunt capacitor is added at bus 2. Two different loads are connected to the bus 3 through distributed transformer of 33kV/400V and which are resistive load of 1MW and variable load. Different fault cases have been created on test-bed for tuning the fuzzy membership function and fuzzy rules. The Power system model is simulated in the MATLAB Simulink software and fundamental components of three phase currents are obtained by using Discrete Fourier transform (DFT) and positive and zero sequence currents are obtained by using sequence analyzer block of Simulink. During the analysis of the data it is observed that depending on the type of fault i.e. line to ground faults, line to line faults, line to line to ground faults or three

phases fault, the waveform changes accordingly. It is significant to mention that during fault the voltage tends to decrease and current tends to increase.

The characteristic features of different types of fault are found out in terms of  $\Delta 1$ ,  $\Delta 2$ ,  $\Delta 3$  and  $\Delta 4$ , which are calculated as described below.

$$\Delta 1 = \frac{I_a - I_b}{\max(I_a, I_b, I_c)}$$

$$\Delta 2 = \frac{I_b - I_c}{\max(I_a, I_b, I_c)}$$

$$\Delta 3 = \frac{I_c - I_a}{\max(I_a, I_b, I_c)}$$

$$\Delta 4 = \frac{I_0}{I_1}$$

Where  $I_a$ ,  $I_b$ , and  $I_c$  represent the sample of three phase currents.  $I_0$  and  $I_1$  are zero sequence and positive sequence currents. Fuzzy rule based method for fault classification is developed on the basis of  $\Delta 1$ ,  $\Delta 2$ ,  $\Delta 3$  and  $\Delta 4$ . Zero sequence current ( $I_0$ ) has been taken into account to detect the presence of ground fault and  $\Delta 4$  represents the ground fault detection.

### III. IMPLEMENTATION OF FUZZY LOGIC APPROACH

The values of  $\Delta 1$ ,  $\Delta 2$ ,  $\Delta 3$  and  $\Delta 4$  are three inputs to the fuzzy classifier, used to classify nature of the fault; the general structure of Fuzzy Inference System (FIS) used in this technique is shown in Figure 2.

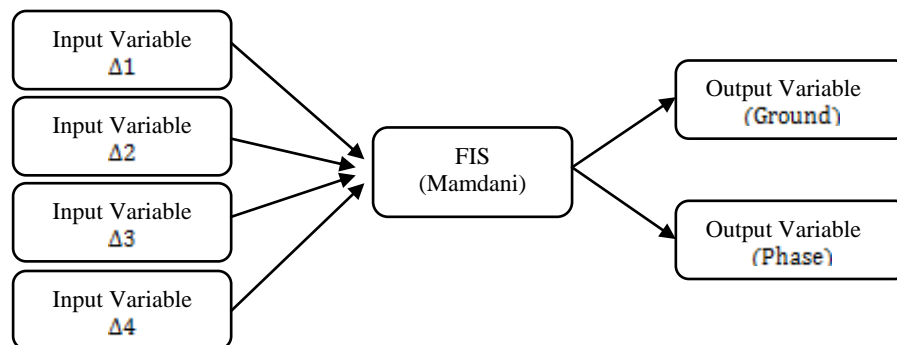

Figure 2: Fuzzy Inference System

Fuzzy rule base for fault classification:

- If  $\Delta 1$  is high and  $\Delta 2$  is medium and  $\Delta 3$  is low and  $\Delta 4$  is high then trip output is AG;
- If  $\Delta 1$  is low and  $\Delta 2$  is high and  $\Delta 3$  is medium and  $\Delta 4$  is high then trip output is BG;
- If  $\Delta 1$  is medium and  $\Delta 2$  is low and  $\Delta 3$  is high and  $\Delta 4$  is high then trip output is CG;
- If  $\Delta 1$  is medium and  $\Delta 2$  is high and  $\Delta 3$  is low and  $\Delta 4$  is high then trip output is ABG;
- If  $\Delta 1$  is low and  $\Delta 2$  is medium and  $\Delta 3$  is high and  $\Delta 4$  is high then trip output is BCG;
- If  $\Delta 1$  is high and  $\Delta 2$  is low and  $\Delta 3$  is medium and  $\Delta 4$  is high then trip output is ACG;
- If  $\Delta 1$  is medium and  $\Delta 2$  is high and  $\Delta 3$  is low and  $\Delta 4$  is low then trip output is AB;
- If  $\Delta 1$  is low and  $\Delta 2$  is medium and  $\Delta 3$  is high and  $\Delta 4$  is low then trip output is BC;
- If  $\Delta 1$  is high and  $\Delta 2$  is low and  $\Delta 3$  is medium and  $\Delta 4$  is low then trip output is AC;
- If  $\Delta 1$  is medium and  $\Delta 2$  is medium and  $\Delta 3$  is medium and  $\Delta 4$  is low then trip output is ABC;

The triangular membership function has been used to present different fuzzy variables in the antecedent and consequent parts of the fuzzy rules as shown in Fig. 3, 4 & 5. Extensive studies have been carried out to select proper triplet values of triangular membership function of  $\Delta_1$ ,  $\Delta_2$ ,  $\Delta_3$  and  $\Delta_4$ . The selected triplets for triangular membership function of fuzzy variables in antecedent parts and consequent part are shown in Tables 1, 2 and 3 respectively for inputs.

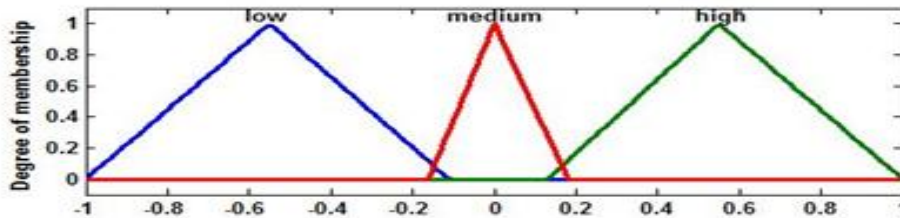

Figure 3: Triangular membership functions for inputs

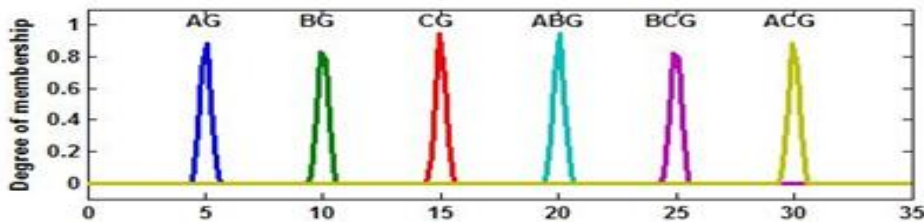

Figure 4: Triangular membership functions for outputs of ground fault

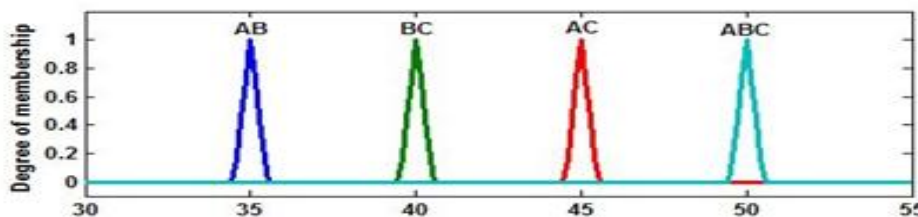

Figure 5: Triangular membership functions for outputs of phase fault

Table 1: Fuzzy variables in the antecedent parts of fuzzy rules for  $\Delta_1$ ,  $\Delta_2$ ,  $\Delta_3$

Input Variables	Triangular Triplets		
	A	B	C
Low	-1	-0.55	-0.11
Medium	-0.16	0	0.18
High	0.14	0.56	1

Table 2: Fuzzy variables in the antecedent parts of fuzzy rules for  $\Delta_4$

Input Variables	Triangular Triplets		
	A	B	C
Low	0	0.05	0.14
High	0.1	0.55	1

Table 3: Fuzzy variables in the antecedent parts of fuzzy rules for  $\Delta_4$

Input Variables	Triangular Triplets		
	A	B	C
AG	4.5	5	5.5
BG	9.5	10	10.5
CG	14.5	15	15.5
ABG	19.5	20	20.5
BCG	24.5	25	25.5
ACG	29.5	30	30.5
AB	34.5	35	35.5
BC	39.5	40	40.5
AC	44.5	45	45.5
ABC	49.5	50	50.5



IV. SIMULATION RESULTS

To validate the proposed fault classification approach, simulation studies have been carried out on a 33kV, 3 phase distribution network with D-STATCOM using MATLAB. The outputs for fuzzy classifier for ground faults and phase faults are shown in Table 4(a), (b) and 5. The proposed logic detects and classifies the fault accurately. The results show that the proposed logic is efficient and appropriate.

Table 4(a): Outputs of fuzzy classifier for ground faults

Fault	For $R_f = 1 \Omega$					For $R_f = 50 \Omega$				
	$\Delta 1$	$\Delta 2$	$\Delta 3$	$\Delta 4$	Fuzzy output	$\Delta 1$	$\Delta 2$	$\Delta 3$	$\Delta 4$	Fuzzy output
AG	0.789	0.013	-0.802	0.607	5.021	0.419	-0.047	-0.371	0.274	5.015
BG	-0.792	0.770	0.022	0.608	9.975	-0.371	0.418	-0.047	0.274	9.975
CG	0.014	-0.803	0.788	0.607	14.98	-0.047	-0.371	0.419	0.274	14.98
ABG	0.122	0.701	-0.824	0.322	20	-0.026	0.404	-0.377	0.226	19.99
BCG	-0.784	-0.034	0.819	0.320	25	-0.377	-0.026	0.404	0.226	24.99
CAG	0.796	-0.827	0.031	0.321	29.99	0.404	-0.377	-0.026	0.226	30

Table 4(b): Outputs of fuzzy classifier for ground faults

Fault	For $R_f = 100 \Omega$				
	$\Delta 1$	$\Delta 2$	$\Delta 3$	$\Delta 4$	Fuzzy output
AG	0.233	-0.035	-0.197	0.158	4.929
BG	-0.197	0.233	-0.035	0.158	9.975
CG	-0.035	-0.197	0.233	0.158	15.05
ABG	0.007	0.207	-0.215	0.144	19.95
BCG	-0.215	0.007	0.207	0.144	24.93
CAG	0.208	-0.215	0.007	0.144	30.1

Table 5: Outputs of fuzzy classifier for phase faults

Fault	For $R_f = 0.01 \Omega$				
	$\Delta 1$	$\Delta 2$	$\Delta 3$	$\Delta 4$	Fuzzy output
AB	0.027	0.741	-0.768	0.000	35
BC	-0.770	0.027	0.742	0.000	40
CA	0.758	-0.781	0.023	0.000	45
ABC	0.088	-0.085	-0.002	0.000	50

V. ACKNOWLEDGEMENT

I would like to thank my supervisor **Asst. Prof. Lavleen Kaur**, Department of Electrical and Electronics Engineering for his immense support and enlightened guidance for this research work which I have developed as an M.Tech. IV semester student. I am very grateful for the inspiring discussions with all my faculties. Their valuable support and path-guiding suggestions have helped me to develop this work.

VI. CONCLUSION

A fuzzy logic based technique has been presented for the detection and classification of faults on distribution network with D-STATCOM. The proposed technique requires the post fault currents of all three phases at sending end of the distribution system. In this presented method, different rules have been framed for all types





of ground and phase faults. The respective input fed to the fuzzy classifier systems to classify nature of the fault. Simulation has been performed by considering various conditions to satisfy the efficiency of the presented technique. Simulation was carried to support the results of the proposed technique. The simulation results have led to conclude that the technique is quiet robust.

## REFERENCES

- [1.] M. Khederzadeh, T. S. Sidhu, "Impact of TCSC on the protection of transmission lines", IEEE Trans. on Power Delivery, Vol. 21, No. 1, pp. 80-87, 2006.
- [2.] W. Weiguo, Y. Xianggen, Y. Jiang, D. Xianzhong, C. Deshu, "The impact of TCSC on distance protection relay", in Proc. of Power System Technology (POWERCON) International Conference, Beijing, 1998, pp. 382-388.
- [3.] A. Kazemi, S. Jamali and H. Shateri, "Effects of STATCOM on Distance Relay Tripping Characteristic", IEEE Transmission and Distribution Conference and Exposition, Dalian, 2005, pp. 1-6.
- [4.] Z. Wen-Hao, L. Seung-Jae, C. Myeon-Song, O. Shigeto, "Considerations on Distance Relay Setting for Transmission Line with STATCOM", In IEEE Power and Energy Society General Meeting, Minneapolis, MN, 2010, pp. 1-5.
- [5.] A. Kazemi, S. Jamali and H. Shateri, "Effects of SMES Equipped SSSC on Distance Relay Tripping Characteristic", IEEE Transmission and Distribution Conference and Exposition, Chicago, IL, 2008, pp. 1-6.
- [6.] S. Jamali, A. Kazemi and H. Shateri, "Distance Relay Over-Reaching due to SSSC Presence on Second Circuit of Double Circuit Line", In proceedings of 3rd IEEE Conference on Industrial Electronics and Applications (ICIEA 2008), Singapore, 2008, pp. 918-923.
- [7.] A. Ghorbani, B. Mozafari, A. M. Ranjbar, "Digital distance protection of transmission lines in the presence of SSSC", International Journal of Electrical Power & Energy Systems, Vol. 43, pp. 712-719, 2012.
- [8.] Netam G, Yadav A. Fault detection, classification and section identification on distribution network with D-STATCOM using ANN. International Journal of Advanced Technology and Engineering Exploration, 2016, Vol 3(23); ISSN (Print): 2394-5443 ISSN (Online): 2394-7454.
- [9.] Ferrero A, Sangiovanni S, Zappitelli E. A fuzzy-set approach to fault-type identification in digital relaying. IEEE Transactions, Power Delivery. 1995 Jan; 10(1):169-75.
- [10.] Wang H, Keerthipala WWL. Fuzzy-neuro approach to fault classification for transmission line protection. IEEE Transactions, Power Delivery. 1998 Oct; 13(4):1093-104.
- [11.] Das B, Reddy VJ. Fuzzy-logic-based fault classification scheme for digital distance protection. IEEE Transactions, Power Delivery. 2005 Apr; 20(2):609-16.
- [12.] Dash PK, Pradhan AK, Panda G. A novel fuzzy neural network based distance relaying scheme. IEEE Transactions, Power Delivery. 2000 Jul; 15(3):902-7.
- [13.] Samantaray SR. A systematic fuzzy rule based approach for fault classification in transmission lines. Applied Soft Computing. Elsevier. 2013 Feb; 13(2):928-38.
- [14.] Mahanty RN, Gupta DPB. A fuzzy logic based fault classification approach using current samples only. Electric Power Systems Research. Elsevier. 2007 Apr; 77(5-6):501-7.
- [15.] Damaraju R, Lalitha SVLNL. A fuzzy controller for compensation of voltage sag/swell problems using reduced rating dynamic voltage restorer. Indian Journal of Science and Technology. 2015 Sep; 8(23):1-6.