

SMART LICENSE BASED VEHICLE SAFETY AND SECURITY SYSTEM

M.Saravanan¹, R.Prasannavenkatesh², S.Poovitha³,

B.Thiruvvarasu⁴, C.Prathepa⁵

^{1,2,3,4,5}Electronics and Communication Engineering, SNS College of Technology, (India)

ABSTRACT

To prevent non-licensees from driving and therefore causing accidents, a new system is proposed. An important and very reliable identification method is QR code based authentication for driving. The proposed system consists of smart license as in the form of QR code in which license number of a particular person is converted in the form of QR code along with the person details. Vehicle such as cars, bikes should have a QR code reader that is QR scanner capable of reading the codes of license. A person, who wants to drive the vehicle, should show the QR code (license) in the vehicle and after verification of QR code with the vehicle, he/she can proceed for ignition, if QR code does not match with particular vehicle, ignition will not work. The system consist of GSM and GPS. This increases the security of vehicles and also ensures safe driving by preventing accidents. The system implementation ensures that license is mandatory to who are all driving and to avoid driving with expired license. The system also provides different speed limit for different users via the smart license.

Keywords: GPS, GSM, QR Code, QR Scanner, Smart License.

INTRODUCTION

In this technological world vehicle theft cases are higher than any other time, it has gotten to be fundamental to give a vehicle a absolute security with the main user authentication. Vehicle focal locking framework guarantees the best ensure to secure your vehicle from various types of burglary cases. It is a vehicle security system that offers fantastic insurance to your vehicle. However this framework couldn't demonstrate to give complete security and openness to the vehicle in the event of burglary. So a more created framework makes utilization of an inserted framework focused around GSM innovation. The outlined and created framework is introduced in the vehicle. Whether one is holder of single vehicle or in excess of 1000, Vehicle Tracking System (VTS) is an answer for spot, track and secure your portable resources. It is intended for exact and ongoing following and reporting of your vehicles, regardless of where it is placed. Combination of high-affectability GPS units in vehicle following frameworks has empowered these gadgets to work in different varieties of situations, for example, characteristic ravines, urban gulches and much under substantial foliage, the length of system scope is solid. The applications incorporate observing driving execution of a guardian with a teenager driver. Vehicle following frameworks acknowledged in shopper vehicles as a burglary avoidance and recovery gadget. In the event that the burglary recognized, the framework sends the SMS to the vehicle holder. After that vehicle

manager sends the SMS to GSM modem appended to the controller, issue the important signs to stop the robbery.

The main aim of the present research is to design and develop an advance and robust security system for vehicles that can prevent theft and provide information on accidents. The system being developed through the present work uses GPS and GSM system and can be made affordable so that it can be used in low cost vehicles even in two wheelers.

This paper aims to introduce a hardware architecture which detects the QR code as well as the validity of the license of the driver and takes a robust decision to turn on or off the ignition system based on the validity. Section II describes the smart license and Section III describes the architecture. Section IV elucidates the QR code matching algorithm followed by Section V describing about the QR Reader. Section VI illustrates the Controller Principle followed by Ignition control in VII. The Results and conclusion in Section VIII and IX.

II.SMART LICENSE

The license issued by the Government is a smart license which stores different fields such as name, license no., date of expiry, QR code of 10 members, type of license and blocked status of the license as well as QR code templates. These QR code templates are derived from the QR scanner.

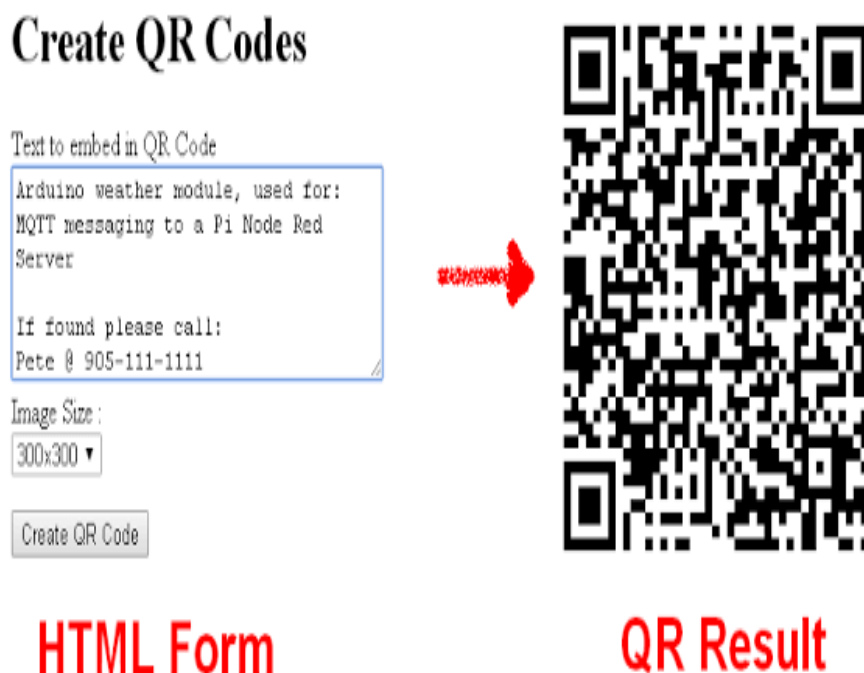

Fig. 1: QR code template Generation.

The QR code sensor takes a digital digits from a QR code of a license number. The QR code scan detects the ridges and valleys of a QR code and converts them into ones and zeroes. Complex algorithms analyse this QR scan to identify characteristics of the QR code, known as the "minutiae". Minutiae are stored in a QR template (a data file usually smaller than the initial scans). There are different types of scanner for QR codes. This types of codes can be very efficient and easy for construct and use.

III. SYSTEM ARCHITECTURE

The system consists of smart license reader, controller module, ignition system module and the smart license which is showed into the system by the user. A QR code match causes the data pins to be in a high logic level and ideally output about 5volts while a QR code mismatch makes the data pins to be in a low logic level and ideally output 0volts. An interface control circuit was constructed to link the PC parallel port to the ignition system of a vehicle. This circuit provides a high degree of electrical isolation between the PC and the ignition system which operate at different voltage levels, through the use of component called optocouplers.

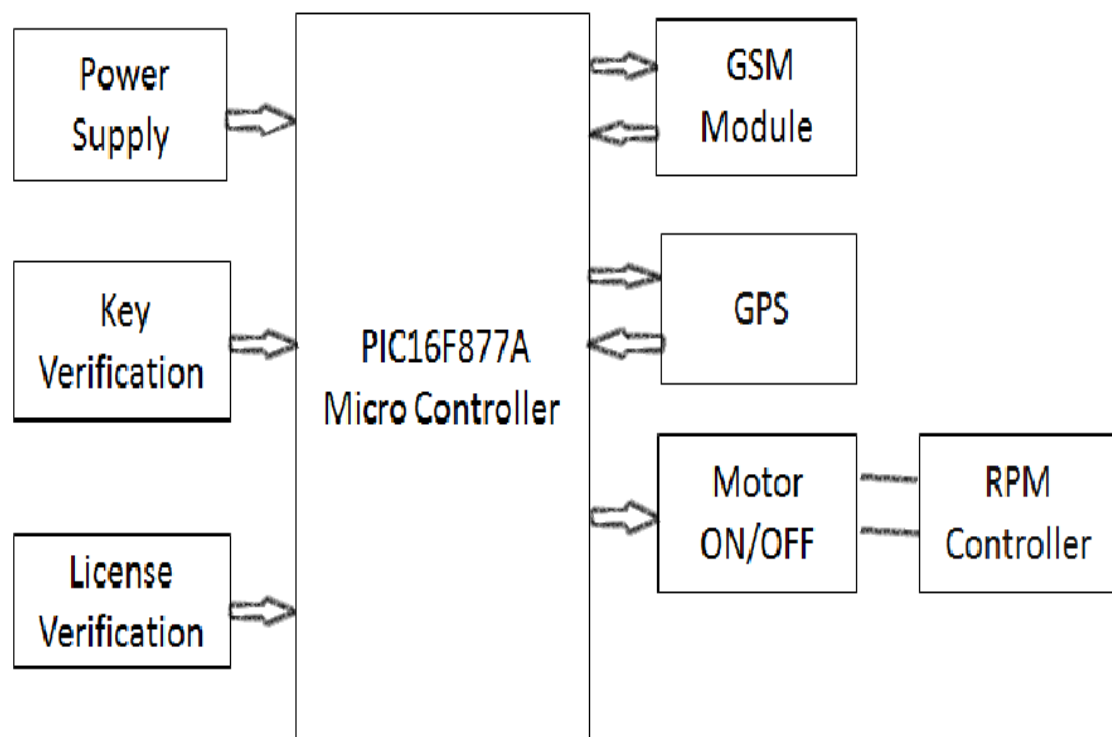
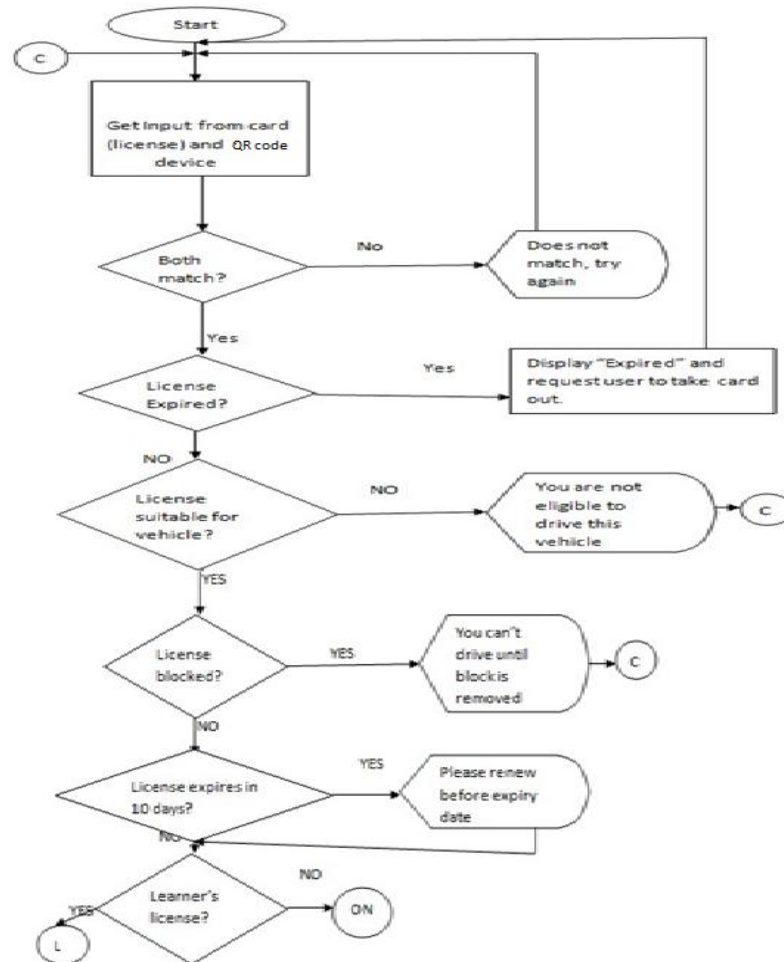

Fig. 2: System Architecture.

IV. QR CODE BASED LICENSING SYSTEM

The circuit also provides capabilities for the controlling the ignition system via the interconnection of electronic components such as relays, bipolar junction transistors, resistors and diodes. Three wires from the ignition system of a vehicle are required to be connected to the interface circuit. When the parallel port data pins which form part of the connection to the interface circuit are in a HIGH logic level, the interface circuit is triggered to ignite the vehicle. On the other hand, the vehicle is not ignited when the circuit is in a LOW logic level. The principal of the prototype system are the QR code recognition software and the interface control circuits which are to form a continuous connection with a vehicle ignition system. The interaction between the various blocks are graphically represented in Fig. 2.

FLOWCHART:



V. SMART LICENSE READER

The smart license is showed in the scanning part of the reader. The QR reader integrates with it a code of the user. This setup increases security by adding “something you are” along with “something you have”. When a QR code of the user is received, it is analysed for its minutiae information and is matched with the template stored in the card to find out if the QR code match. The process is depicted.

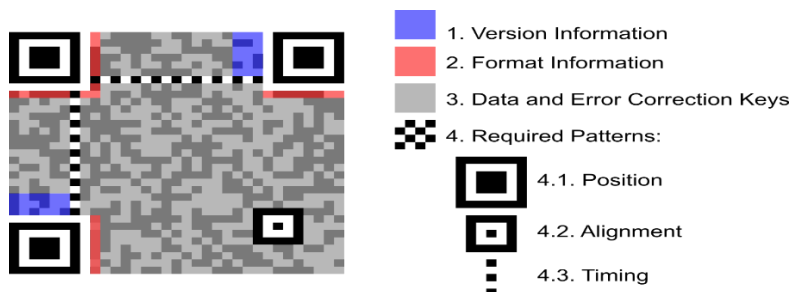

VI. CONTROLLER

The role of the controller is to enable the logic flow. The microcontroller is fed with the required input signals from card reader. The card reader sends signals, each to individual pins of the microcontroller, and the signals include QR code matching information, license expiry status, license suitability status and license blocked

status, all in the form of bits. The microcontroller then branches out to any one of the logical paths and delivers the output at one of its pins, which is used by the ignition control unit. The flow logic also includes checking of expiry of the license. If the license expires in 10 days, it prompts the user to renew the license, once the license expires, the ignition does not happen. When the user holds a learner's license, it accepts the license after the QR code matches, then it prompts the user to insert a valid license and once again the checking process continues. The valid license is to be present in the vehicle until the vehicle is switched off. If the license is taken out before ignition is OFF, the vehicle automatically comes to OFF, and this ensures that the license is not used in another vehicle to switch it ON. We have implemented the proposed prototype using PIC 16F877 microcontroller. PIC microcontroller can also be used if the system is going to be more sophisticated and makes use of interrupts to control the switching ON and OFF of the ignition system. PIC 16F877 from Microchip is a powerful yet easy-to-program (only 35 single word instructions).

FLASH-based 8-bit microcontroller packs PIC16F877 features 256 bytes of EEPROM data memory, an ICD, 8 channels of 10-bit Analog-to-Digital (A/D) converter, 2 additional timers, 2 capture/compare/PWM functions, the synchronous serial port can be configured as either 3-wire Serial Peripheral Interface (SPI) or the 2-wire Inter-Integrated Circuit (I²C) bus and a Universal Asynchronous Receiver Transmitter (USART). All of these features make it ideal for more advanced level A/D applications in automotive, industrial, appliances and consumer applications. All port connectors are brought out to standard headers for easy connect and disconnect. All the necessary support components are included, together with a Power and Programming LED for easy status indication. Plus a reset switch for program execution and a RS232 connection for data transfer to and from a standard RS232 port, available on most computers. The PIC16F877 Controller is the ideal solution for use as a standard controller in many applications. The small compact size combined with easy program updates and modifications, make it ideal for use in machinery and control systems, such as alarms, card readers, real-time monitoring applications and much more. The input to the PIC microcontroller is the result of the keypad (QR code matching algorithm) through port pins RB0 to RB7. The port D is configured as output port is connected to the LCD to display the result of the QR code matching(keypad). The port C can be directly connected to the ignition control(Motor).In the simulation we used keypad and motor instead of QR input to the microcontroller and ignition system output. The pins RC6 and RC7 of port C is connected to the motor. This makes the proposed system user friendly.

VII. IGNITION CONTROL

The ignition system of an internal-combustion engine is an important part of the overall engine system that provides for the timely burning of the fuel mixture within the engine. The ignition system is usually switched on/off through a lock switch, operated with a key or code patch. The part of the ignition system that first initiates the process of moving a vehicle is the key system in conjunction with the kick starter. A wire from the battery in the vehicle connects to the kick starter and other wires connect the kick starter to the key system. When the key in the ignition system is turned once, two wires coming from the kick starter to the key system are bridged. This causes the engine and some other parts of the vehicle to be put in a READY or ON state. Turning the key again makes a third wire to temporarily join the already bridged wires, causing voltage to flow from the battery to the necessary parts vehicle so as to enable the vehicle move. The ignition control is brought about by

placing a relay between the battery and the ignition key unit of the vehicle. The control of the relay is by a signal from the microcontroller. This signal is activated when the logic flow presented earlier satisfies. The relay on successful turn on, gives a feedback to the microcontroller. A solenoid valve attached to the fuel pipe of the engine opens when this feedback is obtained. If feedback was not received, then it is understood that the relay was manipulated and so the solenoid does not open thus preventing the engine from starting. The ignition control is thus made tamper-proof.

VIII. RESULTS

The output of each stage of the QR code detection algorithm which is implemented. The simulation was done using Proteus software. The output from Proteus is sent as an input to PIC16F877 through serial communication. PIC Microcontroller is programmed using MP LAB. The simulation is also performed using Proteus Professional 7 on Windows 8. The hex file generated from the MP LAB compiler is dumped into the PIC microcontroller in Proteus software and it is then executed. The result of the QR code matching is displayed on the LCD screen. The output of the PIC microcontroller can be connected to the ignition of the vehicle. In the simulation figure instead of scanner a keypad is used. The QR Code reads the data and display the appropriate message. Here key is pressed to display messages and to run the motor according to the status.

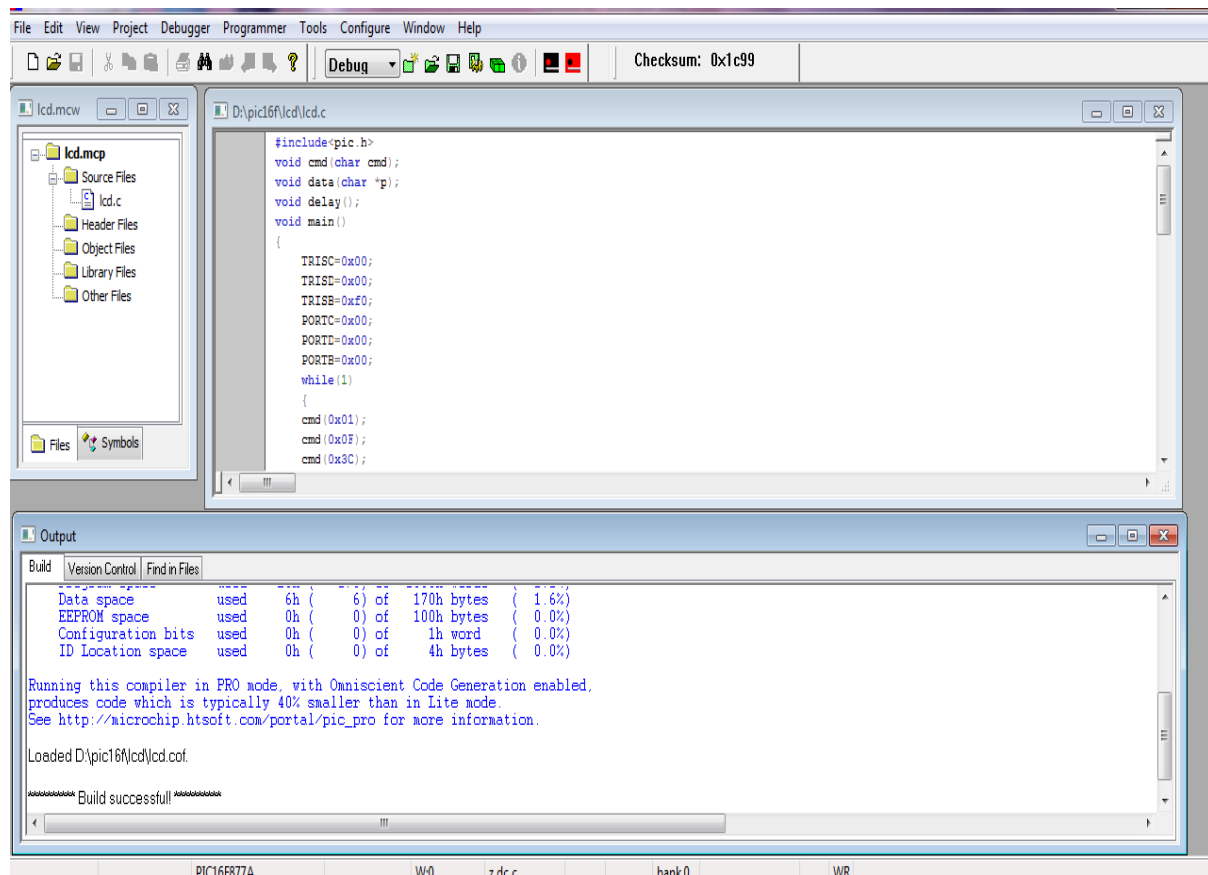

Fig. 3. Program in MPLab

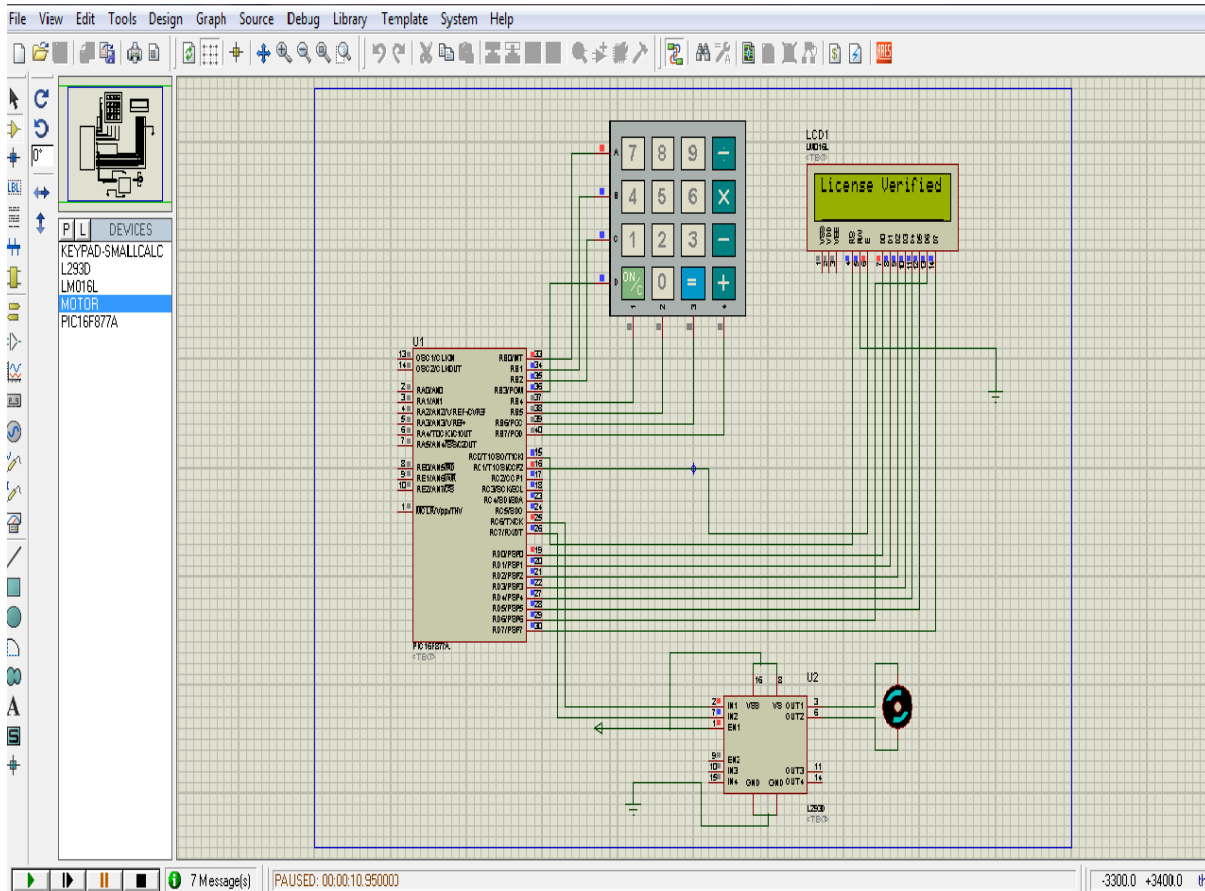

Fig. 4. Simulation Output

IX. CONCLUSION AND FUTURE PROSPECTS

The above input and output analysis of the proposed system proves that the vehicle can be ensured that it is been driven only by the authorized persons. The system also provides facility for the learner’s licenses to drive by keeping a licensed person near them. It also gives time to get the system repaired if any malfunction exists. Though implementation of the proposed system may take time, it would be of great use for the safety of drivers and irregularities can be kept at check without any loopholes. The developed prototype serves as an impetus to drive future research, geared towards developing a more robust and embedded real-time QR code based ignition systems in vehicles. The present module can be interfaced with GPS / GSM module which would be of great use in future. The combined module can be used to monitor from remote location about the vehicle. The data can be used to monitor about the person who is driving the vehicle, by this way, theft can be minimized since it would help to find the person driving along with location details.

REFERENCE

- [1]. Shital Y. Gaikwad and Maheshwari "V. C, Security System for Car using RFID, Thumb Impression, Steering wheel Lock Based on ARM 7" International Journal of Current Engineering and Technology Vol.4, No.3 (June 2014)
- [2]. PriyaDarshini and Prasannabalaje S.M , "Multilevel Security System for Automotives using RFID and Biometric Techniques in Lab view" International Journal of Advanced Research in Electrical, Electronics and Instrumentation Engineering Vol. 2, Issue 4, April 2013.
- [3]. Omidiora E.O., Fakolujo O.A., Arulogun O.T., Aborisade D.O.,(2011), "A Prototype of a Fingerprint based Ignition System in Vehicles", European Journal of Scientific Research, ISSN 1450-216X Vol.62 No.2(2011),pp. 164-171.
- [4]. Visa M. Ibrahim, Asogwa A. Victor "Microcontroller Based Anti-theft Security System Using GSM Networks with Text Message as Feedback" International Journal of Engineering Research and Development e-ISSN: 2278-067X, p-ISSN: 2278-800X, www.ijerd.com Volume 2, Issue 10 (August 2012), PP. 18-22
- [5]. B. Anusha, P. Vengamamba, P. Swathi, S. Ramya, "Finger print based licensing system for driving" Mekapati Rajamohan Reddy institute of technology and sciences affiliated to JNTUA, Udayagiri, S.P. S. R. Nellore.
- [6]. Prashantkumar R., Sagar V. C.," Two Wheeler Vehicle Security System " ,International Journal of Engineering Sciences & Emerging Technologies, Dec. 2015.
- [7]. Suraja P Joy, Sunitha V S, Sowmiya Devi V R," A Novel Security Enabled Speed Monitoring System for Two Wheelers using Wireless Technology ",International Conference on Circuit, Power and Computing Technologies [ICCPCT],2016.
- [8]. Bhumi Bhatt1, Purvi Kalani2, "Smart Vehicle Security System Using GSM & GPS"International Journal of Engineering And Computer Science ISSN:2319-7242 Volume 4 Issue 6 June 2015
- [9]. R.Ramani1, S.Valarmathy1, "Vehicle Tracking and Locking System Based on GSM and GPS", I.J. Intelligent Systems and Applications, 2013, 09, 86-93 Published Online August 2013
- [10]. Vishal P. Patil, Dr. K.B. Khanchandani, "Design and Implementation of Automotive Security System using ARM Processor," International Journal of Engineering Science and Innovative Technology (IJESIT) Volume 2, Issue 1, January 2013.