

## Vehicle Tracking & Security Systems: A Review

Poornima Mahesh<sup>1</sup>, Dr. Anitha Patil<sup>2</sup>

<sup>1</sup> Research Scholar , <sup>2</sup> Research Supervisor

Singhania University, Pacheri Bari, Rajasthan, (India)

### ABSTRACT

*The evolution in transportation technologies has given rise to the need of increasing road safety. The number of vehicles has hugely increased over past few years. Safety of the public vehicle is essential. Earlier passive systems were used but these cannot be used to find real time location information. Later active systems were developed to transmit the location information in real time. It uses in – vehicle unit, which is a hardware unit installed in the vehicle. The location information is transmitted using Global Positioning System (GPS), and Global System for Mobile (GSM) or General Packet Radio Service (GPRS). A microcontroller can control GPS and GSM/ GPRS modules. Geographical coordinates are obtained at regular intervals using GPS and GSM/GPRS module transmits and updates the location to database. Some sensors (like vibration sensor) can be attached to vehicle, which can be integrated to the system, so in case of accident, notification can be sent to nearby hospital/ police station.*

**Keywords:** GPS, GPRS, GSM, Microcontroller

### I. INTRODUCTION

Vehicle plays an important role in everyone's life, which makes some kind of security system essential. Secondly, road accidents have become so common these days, monitoring and control of vehicle is also required. There can be many causes for accidents like fast/ rash driving, drowsiness, drunk and drive or delay of the driver to apply brake [2]. Ultrasonic braking systems can be installed in vehicles to avoid such delays. Wireless security system using GPS and GSM or GPRS are used for vehicle tracking and anti – theft systems. These technologies have reached to common people. GPS fitted vehicles like cars, ambulances or police vans have become very common today. GPS can be used both for tracking as well as for navigation.

For wireless data transmission, GSM technology is used which sends messages about vehicle information to the user. Further, several security systems are used for anti – theft purpose. A proper fleet management system minimizes the cost and effort with minimum time. However, in spite of various technologies, still there are some lapses, which don't allow the recovery of vehicle. In the next section, several systems which are designed and used for vehicle tracking and anti – theft purpose are discussed.

### II. RELATED WORK

In [1], authors proposed a system which tracks and monitors the vehicle, stops the vehicle if stolen and tracks it online for retrieval. Their system used several modern embedded and communication technologies [3][4]. GPS was used to provide location and time information anywhere on earth. Figure (1) [1] shows the discussed system.

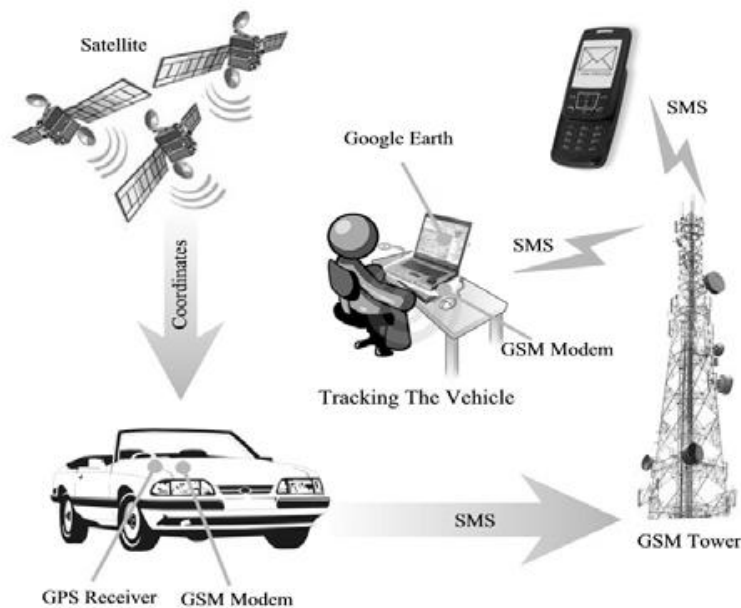

Fig.1 The block diagram of the security system [1]

The system consists of GPS receiver, GSM modem and embedded controller [5]. The user could monitor the location graphically on Google Earth, could stop the vehicle if it was stolen. The user could also view other relevant information of the vehicle as well [6][7]. The system used current sensor to send the analog signal to the microcontroller when the vehicle was running. In case of unauthorized access, after receiving SMS with security code from user, microcontroller sends a signal to the relay to cut off the power. It is comparatively a low cost vehicle tracking and monitoring system.

In [2], author designed and implemented wireless security system in vehicle. It consists of adaptive cruised control, ultrasonic technology, GSM and GPS technology for wireless data transmission. Ultrasonic braking system was used to stop the vehicle automatically when obstacle was sensed. It avoids collision with other vehicle. The vehicle automatically maintains the speed in heavy traffic to adjust a safe gap without the driver to do anything. Sensors track the distance to a lead vehicle and engine and brakes are used to maintain a safe gap. The system block diagram is shown in figure (2)[2].

This system used 32 bit ARM 7 microcontroller, which has high performance and low power consumption. After the detection of accident, GSM sends SMS to family members, nearby police station and hospital whose numbers are already saved in the system. The location of the vehicle where accident took place is also sent. The

system also used 3 – axis accelerometer. It consists of a poly silicon surface micro machined sensor and signal conditioning circuitry to implement an open loop acceleration measurement. The output is the analog voltage which is proportional to acceleration.

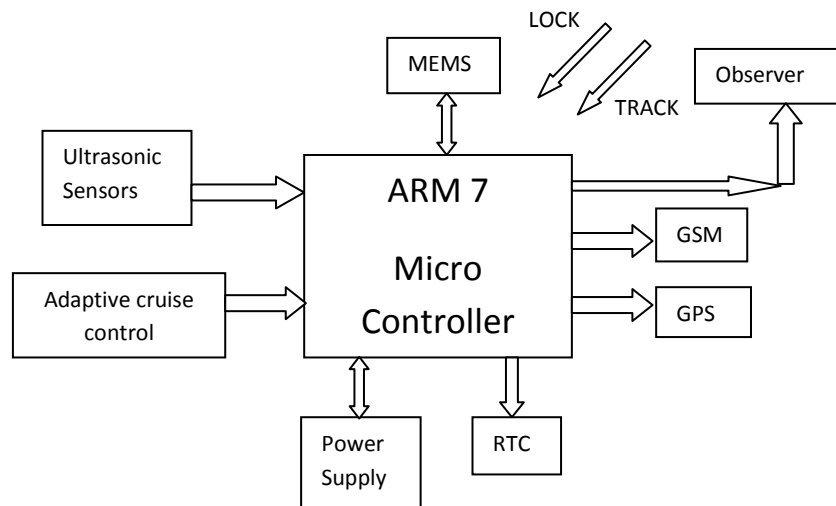

Fig.2 The block diagram of the system [2]

The implemented system also helped to develop a warning and alarm system to notify the driver when under threat. Hence it reduced the risk of accident and saved the life of the driver.

Several other systems are designed and implemented using various microcontrollers, web services, database modules, communication software, social networking and smart phones for vehicle tracking and monitoring. Every system has certain limitations and their own advantages. Major limitation is the dependency of GPS and GSM/GPRS modules on network of wireless system. In case of network unavailability/ failure, the system doesn't work.

### III. CONCLUSION

In this paper, we discussed several low cost vehicle tracking and monitoring systems. Various systems used GPS and GSM/ GPRS modules, microcontroller, ultrasonic sensors and braking system. Such systems not only help user to track and monitor the vehicle but also help them to retrieve the vehicle in case of theft. These systems avoid accident which is a major cause of death. In unavoidable situation, if accident takes place, the system informs nearby police station, hospital and the user's family members. Traffic and accidents have become a big cause of concern these days and more robust systems using latest technologies are required so that these difficulties can be overcome.

### REFERENCES

- [1] Montaser N. Ramadan, Mohammad A. Al – Khedher, "Intelligent Anti – Theft and Tracking System for Automobiles", *International Journal of Machine Learning and Computing*, Volume: 2, No.: 1, Year: 2012

- [2] Akash Choudhary, Yogesh Moon, Prof. Rahul Nawkhare, “ Design and Implementation of Wireless Security System in Vehicle”, *International Journal of Innovative Research in Computer and Communication Engineering*, Volume ; 3, Issue:7, July 2015, ISSN: 2320 - 9801
- [3] J.E. Marca, C.R. Rindt.M. Menally and S.T. Doherty, “A GPS enhanced in – vehicle extensible data collection unit”, *Inst. Transp. Studies, Univ. California, Irvine, CA, Uci – Its – As – Wp – 00 -9, 2000*
- [4] C.E. Lin, C.W. Hsu, Y.S. Lee and C.C. Li, “Verification of unmanned air vehicle flight control and surveillance using mobile communication”, *J. Aerosp. Comput. Int. Commun.*, Volume 1, Number 4, pp 189 – 197, April 2004
- [5] E. M. Tamil, D. B. Saleh, and M. Y. I. Idris, “A Mobile Vehicle Tracking System with GPS/GSM Technology”, in *Proc. 5th Student Conference on Research and Development (SCORED), Permalu Bangi, Malaysia, 2007, pp. 398-402.*
- [6] I. Lita, I. B. Cioc and D. A. Visan, “A New Approach of Automobile Localization System Using GPS and GSM/GPRS Transmission,” in *Proc. Int. Spring Seminar on Electronics Technology, 2006, pp. 115-119.*
- [7] T. K. Kishore, T. S. Vardhan, and N. L. Narayana, “Vehicle Tracking Using a Reliable Embedded Data Acquisition Sysytem With GPS and GSM”, *Int. Journal of Computer Science and Network Security*, vol. 10, no. 2, pp. 286-291, 2010
- [8] V. Kulkarni, and L. N. K. Rao, “Embedded Car Security System on Face Detection”. in *Proc. 2nd National Conference on Information and Communication Technology, New York,2011, no. 40*
- [9] C. E. Lin, C. C. Li, S. H. Yang, S. H. Lin, and C. Y. Lin, “Development of On-Line Diagnostics and Real Time Early Warning System for Vehicles,” in *Proc. IEEE Sensors for Industry Conf., Houston, 2005, pp. 45-51*
- [10] M.Chandra Sekhar Reddy,N. Watthanawisuth, T. Lomas and A.Tuantranont,“Wireless Black Box Using MEMS Accelerometer and GPS Tracking for Accidental Monitoring of Vehicles” *IEEE-EMBS International Conference on Biomedical and Health Informatics IEEE 2012*
- [11] Ajay Kumar Reddy, P.Dileep Kumar, K. Bhaskar Reddy, E.Venkataramana, “Black box for vehicles”, *International Journal of Engineering, Oct 2012*
- [12] Ahmed El Shafee, Mahmoud EI Menshawi, and Mena Saeed, “Integrating Social Network Services with Vehicle Tracking Technologies”, *International Journal of Advanced Computer Science and Applications, Vol. 4, No. 6, 2013*
- [13] X. Fan, W. Xu, H. Chen, and L. Liu, “CCSMOMS: A Composite Communication Scheme for Mobile Object Management System”, in *Proc. 20th International Conference on Advanced Information Networking and Applications, Vienna, 2006, pp. 235–239.*
- [14] R. S. Rempel, and A. R. Rodgers, “Effects of differential correction on accuracy of a GPS animal location system”, *Journal of Wildlife Management, Vol. 61, no. 2, pp. 525-530. Apr 1997.*