

Design consideration for 90 degree steering system in conventional sedan cars

Dr.Ashish Mathew¹, Krishankant², Shubham Rathore³

¹ Professor, ^{2,3} Scholar, Department of Mechanical Engineering,
Vedant College of Engineering & Technology, Bundi, Rajasthan (India)

ABSTRACT

The advanced new technology has led to various modifications in the automobile sector. There is no hard and fast formula to calculate the turning circle but it can be calculated using this; Turning circle radius = $(\text{track}/2) + (\text{wheelbase}/\sin(\text{average steer angle}))$. Zero degree turning radius of a vehicle implies the vehicle rotating about an axis passing through the centre of gravity of vehicle i.e. the vehicle turning at the same place, where it is standing. No extra space is required to turn the vehicle. So vehicle can be turned in the space equal to the length of the vehicle itself. This technology exists in heavy earth movers like excavator which consists of two parts i.e. the upper part cabin and lower part crawler chain. The upper part of excavator can rotate about its centre, so that the direction of cabin can be changed without changing direction of lower part. Conventional steering mechanism involves either the use of Ackerman or Davis steering systems. The disadvantage associated with these systems is the minimum turning radius that is possible for the steering action. This difficulty that is associated with the conventional methods of steering is eliminated by employing a four wheel steering system. In this system, the wheels connected to the front axles are turned opposite to each other, and so are the wheels connected to the rear axle. The wheels on the left half vehicle rotate in one direction and the ones on the right half of the vehicle rotate in the opposite direction. This arrangement of the wheels enables the vehicle to turn 360 degrees, without moving from the spot, i.e. the vehicle has zero turning radius.

I. INTRODUCTION

In highly populated areas it can be difficult to find available parking spots. Frequently parking spots are located on the side of the road, leaving the driver with no choice but to attempt parallel parking. In general it is considered to be a rather challenging maneuver. Since parallel parking requires driving backwards it becomes difficult to coordinate the correct motion of the car. Some drivers have to perform multiple corrections before they park the car properly. In the worst case an accident can occur. A car that can perform parallel parking by itself would save drivers time, especially those that are not very good with parallel parking. In addition cars that can parallel park autonomously in a reliable manner would most probably reduce the number of accidents related to parking. The objective of our work is to implement parallel parking using a car like robot[4]. The robot that we used is of type pioneer 3. We restricted the motion of the robot to model the motion of a car. Using our model we present a solution to the autonomous parallel parking problem

II. STEERING MECHANISMS

2.1 About Hydraulic Power Steering technology is the older one of the two and has been put to use for decades. Unlike earlier systems, modern hydraulic units are speed sensitive and work differently when the car slows down or builds up speed. Hydraulic Power Steering uses belt-driven power steering pump, which creates pressure. The pressurised fluid is then forced into a cylinder for assisting the steering movement. When the driver turns the steering wheel, it opens up the flow or pressurized fluid in such a way that it helps in turning the wheels one-way or the other[5].

2.2 About What is Electric Power Steering?

Electric Power Steering or EPS on the other hand is less complicated and more reliable in the long run. This system uses electronics instead of hydraulics. The whole mechanism works with the help of a control unit with some sensors and an electric motor. When the steering wheel is turned, the motor uses electricity to assist the steering moments required to turn the wheels. At high speeds it makes the steering damping stiffer, therefore making the steering feel 'heavier' or 'weighted' and in turn, safer.

2.3 Components

1 Rack and Pinion: Rack The rack of the steering gear is a circular bar with teeth cut across a part of its length. The steps followed during the generation of rack are as follows: Developing a Virtual Prototype of a Rack and Pinion Steering (RPS) System



Fig-1: Rack and Pinion Pinion

The generation of pinion in ADAMS is done in a manner similar to the gear shaping process (Merritt, 1971). The gear shaping and hobbing are similar in their principle of involute generation. The hobbing is a continuous generation process where the hob is continuously fed into the workpiece, whereas, the gear shaping is an intermittent process where the cutter rack makes series of cut on blank. For each cutting instance during shaping, the rack and blank are moved through a small incremental displacement, as if 72 N. Kamble and S.K. Saha they are in mesh. At the end of rack-stroke, it is withdrawn from the blank and brought to the original position. The principle of gear shaping is used while modelling the pinion in ADMAS. A cylinder of nominal diameter is made first. The pitch diameter of the pinion blank and the line of symmetry of the rack are separated by the amount of profile shift. The cylinder and the cutter rack is oriented to the required helix angle of the pinion.

2.4 Bevel Gear: Two important concepts in gearing are pitch surface and pitch angle. The pitch surface of a gear is the imaginary toothless surface that you would have by averaging out the peaks and valleys of the individual teeth. The pitch surface of an ordinary gear is the shape of a cylinder. The pitch angle of a gear is the angle between the face of the pitch surface and the axis. The most familiar kinds of bevel gears have pitch angles of less than 90 degrees and therefore are cone-shaped[1]. This type of bevel gear is called external because the gear teeth point outward. The pitch surfaces of meshed external bevel gears are coaxial with the gear shafts; the apexes of the two surfaces are at the point of intersection of the shaft axes. Bevel gears that have pitch angles of greater than ninety degrees have teeth that point inward and are called internal bevel gears. Bevel gears that have pitch angles of exactly 90 degrees have teeth that point outward parallel with the axis and resemble the points on a crown. That's why this type of bevel gear is called a crown gear. Miter gears are mating bevel gears with equal numbers of teeth and with axes at right angles.



Fig-2: Bevel Gear

2.5 Internal Gear: A hub gear, internal-gear hub, or just gear hub is a gear ratio changing system commonly used on bicycles that is implemented with planetary or epicyclic gears. The gears and lubricants are sealed within the shell of the hub gear, in contrast with derailleur gears where the gears and mechanism are exposed to the elements. Changing the gear ratio was traditionally accomplished by a shift lever connected to the hub with a Bowden cable, and twist-grip style shifters have become common[2]. Hub gear systems generally have a long and largely maintenance-free life though some are not suitable for high-stress use in competitions or hilly, off-road conditions. Many commuter or urban cycles such as European city bikes are now commonly fitted with 7-speed gearhubs and 8-speed systems are becoming increasingly available. Older or less costly utility bicycles often use 3-speed gear-hubs, such as in bicycle sharing systems. Many folding bicycles use 3-speed gear-hubs. Modern developments with up to 14 gear ratios are available.[5]

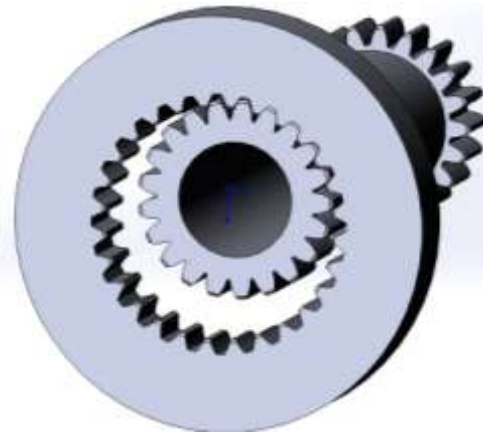

2.6 Chain Drive: Chain drive is a way of transmitting mechanical power from one place to another. It is often used to convey power to the wheels of a vehicle, particularly bicycles and motorcycles. It is also used in a wide variety of machines besides vehicles[4].

2.7 Sprocket: A sprocket or sprocket-wheel is a profiled wheel with teeth, cogs, or even sprockets that mesh with a chain, track or other perforated or indented material. The name 'sprocket' applies generally to any wheel upon which radial projections engage a chain passing over it. It is distinguished from a gear in that sprockets are never meshed together directly, and differs from a pulley in that sprockets have teeth and pulleys are smooth.[5] Sprockets are used in bicycles, motorcycles, cars, tracked vehicles, and other machinery either to transmit rotary motion between two shafts where gears are unsuitable or to impart linear motion to a track, tape etc.

III. CALCULATIONS

Rack and Pinion

$$\text{Addendum} = m = 1.8\text{mm}$$

$$\text{Dedendum} = 1.25 * m = 2.\text{mm}$$

$$\text{Clearance} = 0.25m = 0.5\text{mm}$$

$$\text{Working depth} = 2m = 4\text{mm}$$

$$\text{Whole depth} = 2.25m = 4.5\text{mm}$$

$$\text{Tooth thickness} = 2.1416\text{mm}$$

$$\text{Tooth space} = 1.5708m = 3.1416\text{mm}$$

$$\text{Fillet radius} = 0.4m = 0.8\text{mm}$$

Bevel Gear

$$m = 2\text{mm}$$

$$Z_p = 28$$

$$Z_g = 28$$

$$b = A_0 / 3 = 39.58 / 3 = 13.2\text{mm}$$

$$d_p = m Z_p = 56\text{mm}$$

$$d_g = 56 \text{ mm}$$

$$A_0 = 19.79 * m = 19.79 * 2 = 39.58$$

$$h_a = 1 * m = 2$$

$$h_f = 1.2 * m = 2.4 \text{ mm}$$

$$Y_p = 45$$

$$Y_g = 45$$

3.1 Internal Gear Selection of Internal Gear to support pinion

This a non standard gear fabricated on laser machine as per our requirement

Diameter = 240 mm

No of teeth = 60

Pitch = 5 mm,

matching to pinion Module = 2,

matching to pinion

Gear ratio = 2.88 3.4

3.2 Chain Effort applied

By human both legs = 200 N ,Mass of Shaft $M = 2 \text{ kg}$, $W = 9.81 \text{ N}$,Total breaking load on chain = $200 + 9.81 = 209.81 \text{ N}$ For load , $F = 209.81 \text{ N}$,Selecting Chain -06 B All Data , $F = 8900 \text{ N} > 209.81 \text{ N}$ pitch -9.525mm roller diameter, $d_1 = 6.35 \text{ mm}$ width, $b_1 = 5.72 \text{ mm}$,transverse pitch $p_t = 54.85 \text{ mm}$ $z_1 = 44$ $z_2 = 18$ approximate centre distance, $a = 600 \text{ mm}$ for practical feasibility and may change in the fabrication. No of links, $L_n = 2 * () + z_1 + z_2$
 $2 + z_1 - z_2 \frac{2\pi}{2} * (a) = 159.66 = 160$

3.3 Sprocket For Used

chain no.06 B For $Z = 18$ All Data From Table 14.6 of Textbook of “Design of machine elements” by V. B. Bhandari For $Z = 18$ From table no 14.1 Pitch , $P = 9.525$ Width between inner plates , $b_1 = 5.72$ Roller diameter, $d_1 = 6.35 \text{ mm}$

Transverse pitch $p_t = 10.24$ pitch circle diameter $D = p \sin \frac{\pi}{z} (180/z) = 54.85 \text{ mm}$ Top diameter (Da) $(D_a)_{\max} = D + 1.25p - d_1 = 60.4 \text{ mm}$ Root diameter , $D_f = D - 2r_1$ 4.

IV. CONSTRUCTION

The main components are bevel gear, rack and pinion ,internal gear, wheels, chain sprocket, bearings, steering wheels. In this vehicle we used this arrangement to turn the wheel at 90 degree in a steady state condition. Shaft plays an important role of transmitting power from rack and pinion to internal gear. Here we use ackerman steering mechanism for front wheels and rear wheels follow their motion.

V. WORKING PRINCIPLE:-

In this model, we are transmitting power manually i.e by chain and paddle system. Here we are using chain and paddle arrangement only for transmitting power to wheels. As we rotate steering wheel, bevel gear will give power and motion to rack and pinion and then accordingly shaft will rotate. internal gear is used for support where we used sun and planet gear.

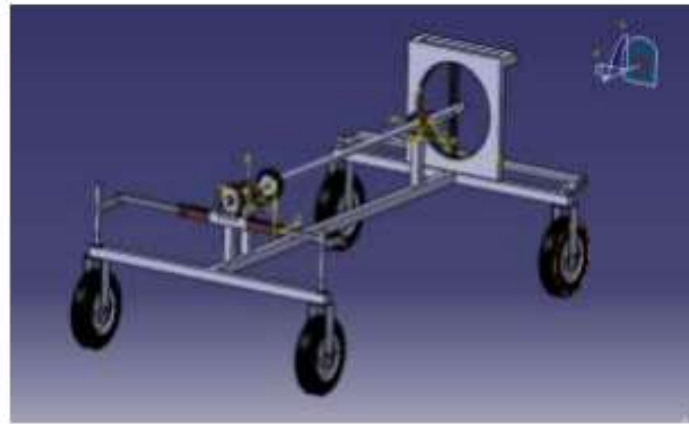

Fig-6: Cad Model

Advantages:-

- Safety
- Comfort
- Control over car
- Improved traction and handling
- Able to transmit torque to all four wheels

VI. CONCLUSION

A vehicle featuring low cost and user friendly steering mechanism has been introduced. This paper focused on a steering mechanism which offers feasible solutions to a number of current maneuvering limitations. A prototype for the proposed approach was developed by introducing separate mechanism for normal steering purpose and 360 steering purpose. This prototype was found to be able to be maneuvered very easily in tight spaces, also making 360° steering possible.

REFERENCES

- [1] S.V. Shirsath, K.R. Jadhav, R.V.Patil, A.V. Mohite, Prof.D.D. Patil, “ZERO TURN VEHICLE”, International Research Journal of Engineering and Technology (IRJET), Volume: 03 Issue: 02, Feb-2016
- [2] Colin Varghese, David Babu, DelwinKuriyakose, Harikrishnan.A.S, Irshad M, Arun Raj A, “Different Modes in Four Wheel Steered Multi-Utility Vehicles”, International Journal of Engineering And Science, Volume:6, Issue 4, April-2016

- [3] Er. Amitesh Kumar, Dr.Dinesh.N.Kamble, “Zero Turn Four Wheel Steering System”, International Journal of Scientific & Engineering Research, Volume 5, Issue 12, December-2014 [4] K.Lohith, Dr. S. R.Shankapal, M. H. MonishGowda, “DEVELOPMENT OF FOUR WHEEL STEERING SYSTEM FOR CAR”, sastech Journal, Volume 12, Issue 1, April 2013.
- [5] SaketBhishikar, VatsalGudhka, Neel Dalal, Paarth Mehta, Sunil Bhil, A.C. Mehta, “DESIGN AND SIMULATION OF 4 WHEEL STEERING SYSTEM”, International Journal of Engineering and Innovative Technology (IJEIT) Volume 3, Issue 12, June 2014
- [6] Mandar Harer , Vaibhav Desai , Ajay Gawal , KirtimanChavan ,Vishal Aradhya” Design and Development of 90 Degree Steering System” 3 International Conference on Ideas, Impact and Innovation in Mechanical Engineering (ICIIIME 2017) ISSN: 2321-8169 Volume: 5 Issue: 6 233 – 239