

DESIGN AND DEVELOPMENT OF INTEGRATED PNEUMATIC CAR JACK

Kaushal H. Pandya¹, Amit V. Sawant², Vinayak S. Gurav³,

Assistant Prof. S S Gurav⁴

*^{1,2,3,4}Mechanical Department, Nanasaheb Mahadik college of Engg.,
Shivaji University Kolhapur (India)*

ABSTRACT

A jack is a device which lifts heavy equipment. The most common form is a car jack, floor jack or garage jack which lifts vehicles so that maintenance can be performed. We make equipment which will lift the vehicle without any manual effort. It is integrated in the vehicle which is simply operated by driver and as per our requirement we lift the wheel.

Keywords: *Air Compressor, DC Valve, FRL Unit, Integrated Pneumatic Jack, Power Screw.2.*

I.INTRODUCTION

When car get punctured or broke down, we have to lift it at certain height. Today, we are using hand operated screw jack to lift it. The screw jack is provided by vehicle manufacturer. To lift vehicle, we have to take it out from vehicle, place it properly under axle. Then, by using manual force, screw is to be rotated. The virtues of using a screw as a machine, essentially an inclined plane wound round a cylinder, was first demonstrated Archimedes in 200BC with his screw used for pumping water. There is evidence of the use of screws in the Ancient Roman world but it was the great Leonardo da Vinci in the late 1400's who first demonstrated the use of a screw jack for lifting loads. With the industrial revolution of the late 18th and 19th centuries came the first use of screws in machine tools from English inventors such as John Wilkinson and Henry Maudsley The most notable inventor in mechanical engineering from the early 1800's was undoubtedly the mechanical genius Joseph Whitworth. Over the past 60+ years, the product has evolved to push, pull, lift, lower and position loads of anything from a few kilos to hundreds of tonnes. Most features now offered our competitors were actually designed and patented Screw Jack & Duff-Norton over the years

II.NEED OF INVENTION

In the world, the fact is that "necessity is the mother of invention" and the necessary condition is that, large effort is required for the manual operation of jacks, so for that reason, it is the need of invention. In the repair and maintenance of automobiles, it is often necessary to raise an automobile to change a tyre or access the bottom of the automobile. According to that, various car jacks have been developed for lifting an automobile from a ground surface. In that case, they are categorized as; Standard jack, pneumatic jack, farm jack,

hydraulic jack. Normally the standard jack uses the power screw for lifting. This standard jack has limited degree of freedom with corresponding link members. In Hydraulic jack, incompressible fluid is used instead of screw for lifting. This is achieved by increasing the fluid pressure in cylinder to uplift the load. Available jacks are typically large, heavy and also difficult to store, transport, carry or move into underside of an automobile. Doing work in a bent or occupying position for a period of time is not ergonomic to human body, i.e. It is not completely desirable in ergonomics point of view. It may give back problem while continuous working with same. Engineering is preferred for making things simpler or improving and effective, for that Car jacks must be easy to use for pregnant women. The general purpose of the project is to minimize the human effort while operating the jack.

III.LITERATURE SURVEY

Thomas J. Prather (2009)^[1]: In this, there was a introduction about vehicle lift system. A drive assembly was mechanically coupled to the piston. The drive assembly was operated in first direction to raise an upper end of the piston with respect to the housing. The drive assembly was operated in a second direction to lower the upper end of the piston with respect to the housing. The drive assembly was coupled to the power supply port which is removable to supply electrical power to the drive assembly.

Farhad Razzaghi (2007)^[2]: In this, electrically powered jack shown for normally raising and lowering of automobile from ground surface. The mechanism may be used in joining with a typical portable car jack, during which the mechanism constitute a power drill, a rod, and a numerous jack adapters.

Manoj Patil (2014)^[3]: In this general article, screw jack is to developed to overcome the human effort. It is actually difficult job to operate for pregnant women and old person. Changing the tyre is not a pleasant experience. Especially women can't apply more force to operate. For that, electric operated car jack is introduced

Lokhande Tarachand (2012)^[4]: This paper referred to optimise the efficiency of square threaded mechanical screw jack by varying different helix angle.

IV. PNEUMATIC JACK

A pneumatic jack is a part of hydraulic jack that is actuated by compressed air - for example, air from a compressor - instead of human work. It saves the effort which exclude the need of the user to actuate the hydraulic mechanism, with potentially increasing speed. In certain circumstances, these jacks are also capable to be operated by normal hydraulic actuation mechanism, by that keeping possession ability, even when source of compressed air is not available.

V. WORKING PRINCIPLE

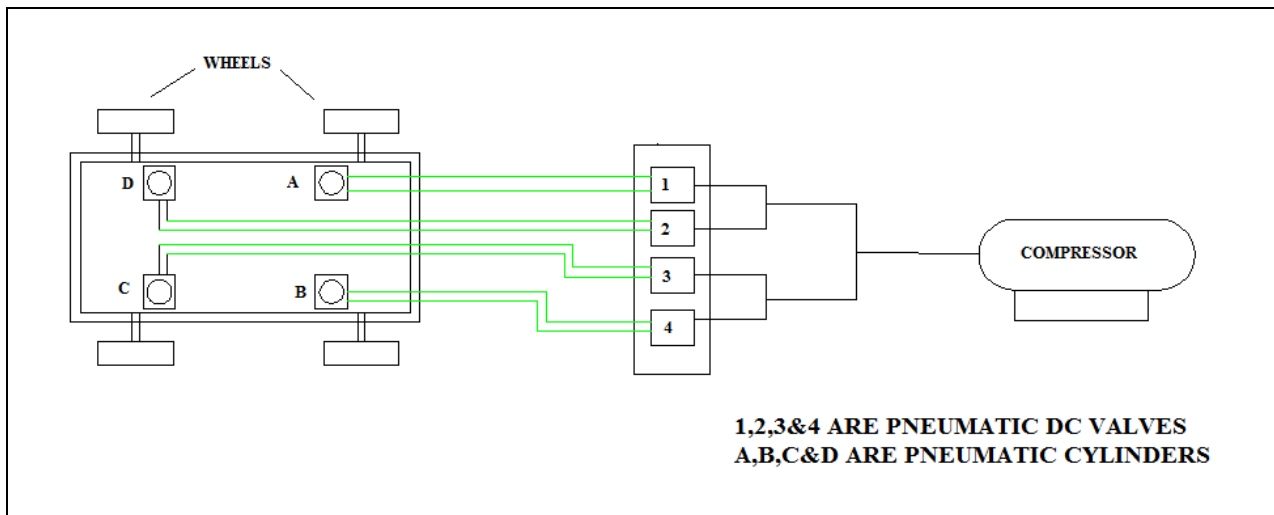

Fig. No.3.1. Layout Of Model

1. Firstly we connect hoses as per our figure.
2. When we giving supply to the compressor then compressor will run.
3. At normal condition compressed air is supply at bottom side.
4. The flow control valve is connected to cylinder for controlling the flow.
5. When we want to lift the one rear wheel then we operate the lever of that pneumatic cylinder so that pneumatic cylinder change the position that is it goes to forward condition so that it lift the vehicle.
6. The circular disc is connected to the end of piston.
7. So piston will goes downward and the rear wheel goes upward
8. In that way we can lift the wheel as per requirement.

VI. DESIGN CALCULATIONS

Consider the total weight of vehicle is 60 kg

The weight lifting by one pneumatic cylinder near wheel is consider-15

Find out the force applied on trailer in N

$$F = 15 \times 9.81 \\ = 147.15 \text{ N}$$

We know the formula

$$F = P \times A$$

Where,

F= Applied Force (N)

P = pressure used (N/mm²)

A =area of cylinder (mm²)

We consider the normal pressure is 5 bar =0.5 N/mm²

$$F = P \times A$$

$$147.15 = 0.5 \times A$$

$$A = 374.71$$

Now we find out the required diameter of cylinder

We know that

$$A = \frac{\pi}{4} \times d^2$$

Where,

A= area of cylinder (mm²)

d = diameter of cylinder (mm)

$$A = \frac{\pi}{4} \times d^2$$

$$374.71 = \frac{\pi}{4} \times d^2$$

$$d = 19.35 \approx 20 \text{ mm}$$

The standard cylinder available in market is 20 mm, 25mm, 32mm

We select 20mm

$$20 \text{ mm} > 19.35 \text{ mm}$$

So we select the diameter of cylinder is 20 mm which is safe.

For pneumatic cylinder $\phi 20 \times 75$

VII. CONCLUSION

This integrated pneumatic car jack is highly desirable jack to become available in vehicles that can be operated by the compressed air. It is highly useful for pregnant lady, old age people. To design easy to operate. To manufacture Low cost working product. To reduce human efforts. To utilize for commercial business .To design low maintenance of product.

VIII. BIBLIOGRAPHY

- [1] V.B. Bhandari, Design of Machine Elements, Tata McGraw-Hill Publication Company Limited, New Delhi.
- [2] PSG, Design Data Book, section- Materials and Machine Elements.
- [3] R.S. Khurmi, Strength of Materials, S. Chand & Company Ltd. New Delhi.
- [4] P.S. Gill, Machine Drawings, S. K. Kataria & Sons.
- [5] R.S. Khurmi, Theory of Machines, S. Chand & Company Ltd. New Delhi.

REFERANCES

- [1] **Thomas J.Prather (2009) “Automated Car Jack”, *International Journal of Current Engineering and Technology (Vol.4, No.4, Aug 2014) E-ISSN 2277 –4106, P-ISSN 2347 – 5161.***
- [2] **Farhad Razzaghi (2007) “Automated Car Jack”, *International Journal of Current Engineering and Technology (Vol.4, No.4, Aug 2014) E-ISSN 2277 –4106, P-ISSN 2347 – 5161.***
- [3] **Manoj Patil, Gaurav Udgirkar, Rajesh Patil and Nilesh, “Automated Car Jack”, *International Journal of Current Engineering and Technology (Vol.4, No.4, Aug 2014) E-ISSN 2277 –4106, P-ISSN 2347 – 5161.***
- [4] **Lokhande Tarachand G., Chatpalliwar Ashwin S. And Bhoyar Amar A., “Optimizing Efficiency of Square Threaded Mechanical Screw Jack by Varying Helix Angle”, *International Journal of Modern Engineering Research (IJMER)(Vol.2, Issue.1, Jan-Feb 2012 pp- a 504-508) ISSN: 2249-6645***
- [5] **“Highly Efficient Motorized Screw Jack”, *International Journal of Computational Engineering Research||Vol, 03||Issue, 5||***
- [6] **“Experimental Investigation of Motorized Screw Jack”, *International Journal of Advanced Research in Biology, Ecology, Science and Technology (IJARBEST) Vol. 1, Issue 8, November 2015.***