

# A RELATIVE STUDY ON UPFC AND DPFC ON THE BASIS OF TOTAL HARMONICS DISTORTION

Rahul Kumar<sup>1</sup>, K. P. Singh<sup>2</sup>

<sup>1</sup>P.G. Student, Department of Electrical Engineering, MMMUT, Gorakhpur, Uttar Pradesh, (India)

<sup>2</sup>Associate Professor, Department of Electrical Engineering,  
MMMUT, Gorakhpur, Uttar Pradesh, (India)

## ABSTRACT

The industrial developments in power electronic devices and circuits prompt finish automation of both transmission and distributed system. And also control the domestic loads. Due to this, there are many problems occur like heating losses, power factor issues, and high temperature. For improvement the harmonics problems, we use new technology Facts devices like UPFC and DPFC. This paper has been compared between UPFC and DPFC.

**Keywords:** UPFC, DPFC, Harmonics, Nonlinear loads.

## I. INTRODUCTION

In present time, Harmonics are big issues present in the voltage and current in power system. Harmonics has developed due to the using of nonlinear loads, diodes, SCR, arc furnaces for many applications. Mainly causes the distortion in current and voltage waveforms. For harmonic analysis, we determined by the formula of total harmonics distortion (THD).

$$V_{\text{THD}} = \sqrt{\frac{\sum_1^n V_n^2}{V_1}}$$

Where n shows the no. of harmonics and V1 is voltage with fundamental frequency

For improving the harmonics, we use many methods which conclude filters, Facts devices, UPFC, DPFC, compensators etc. This paper has been represent the comparison between UPFC AND DPFC with help of Simulink model on the basis of total harmonics distortion. And reduced harmonics.

## II. UNIFIED POWER FLOW CONTROLLER

FACTS- devices give a good alternation to vary the working situations and get improvement the usage of existing installations. International for many uses FACTS – devices has been presented. One of such application is modification of power quality disturbances, especially harmonics. An UPFC is a FACTS-devices which controls the current, voltage, reactive power and real power concurrently. It is combination between shunt and

series converter connected with DC link which provide necessary voltage. And also used for shunt compensation device, phase shifting.

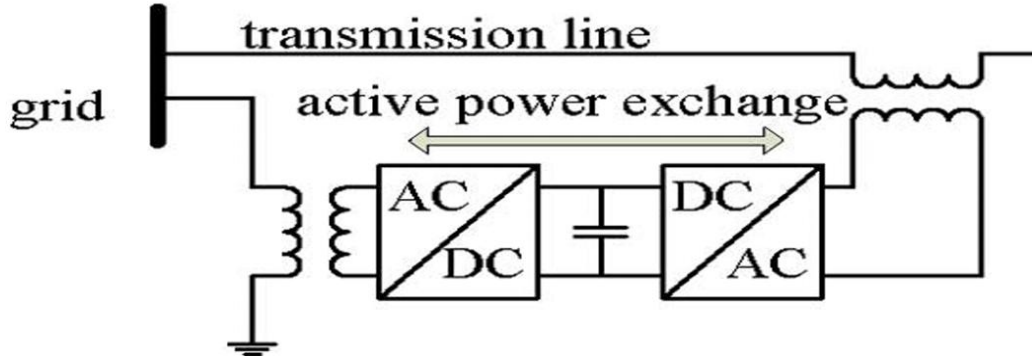

Fig.1 UPFC Configuration

A SIMULINK model is developed with FACT-devices. And harmonics analysis with bus voltage with sag and swell. Compare with DPFC.

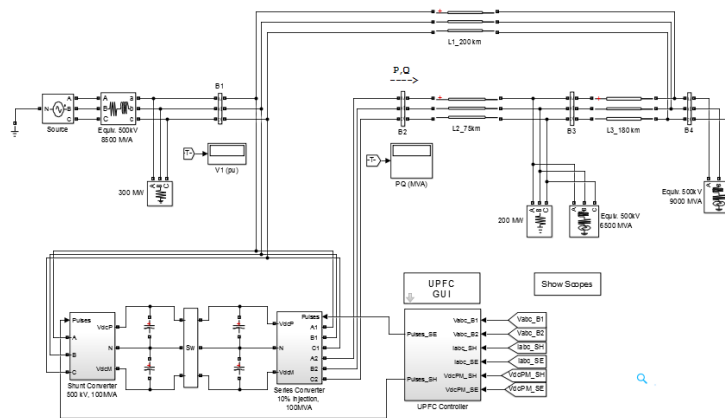

Fig 2: UPFC connected to the load bus for harmonics reduction

### III. DISTRIBUTED POWER FLOW CONTROLLER

DPFC is derived from the UPFC. It is used for better reliability and less cost in comparison to the UPFC. Within the DPFC, DC link is removed between series and shunt converter and a many low ratings single phase converters are used in place of the High ratings three phase converters for less cost. DPFC is consists STATCOM and SSSC. STATCOM as a shunt converter and SSSC as a series converter. In DPFC, active power has been exchanged among the shunt and series converters through a common connection of the AC terminals.

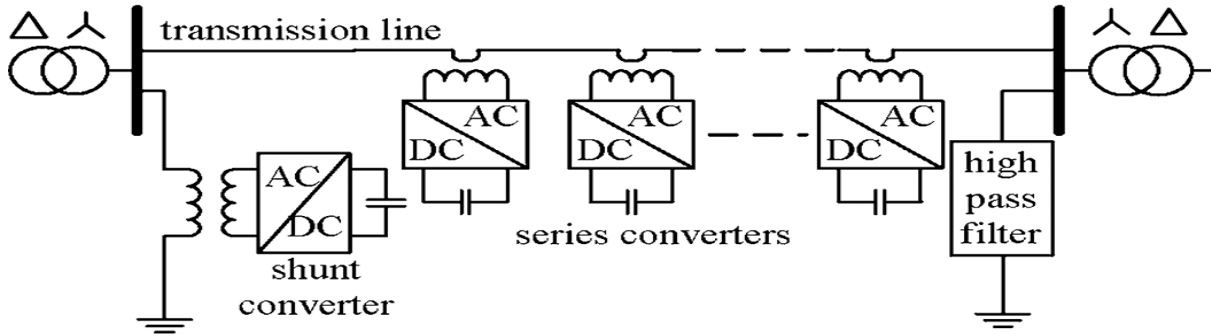

Fig.3 Construction of DPF

A SIMULINK is developed with controlling devices .And perform the harmonics analysis with bus voltage. In the system, controllers are used for improvement of the harmonic distortions.

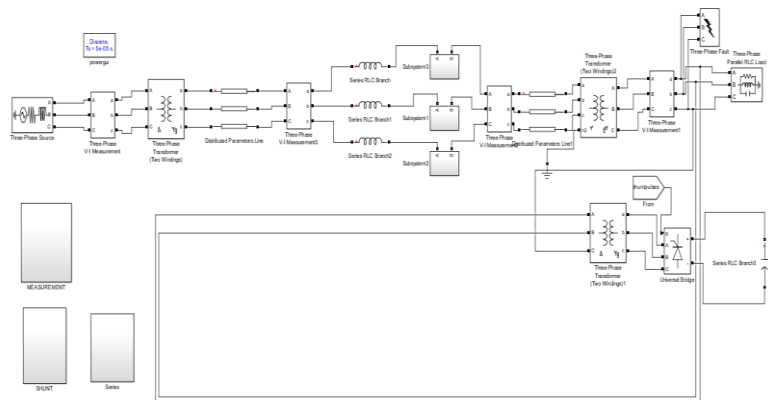

Fig. 4 : DPF connected to the load bus for harmonics reduction

IV. SIMULATION RESULTS

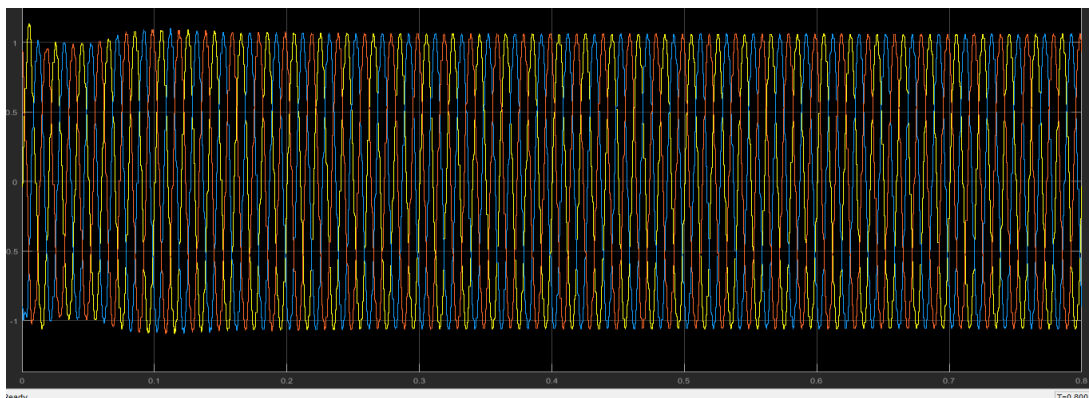

Fig. 5 Harmonics reduction in bus voltage with UPFC

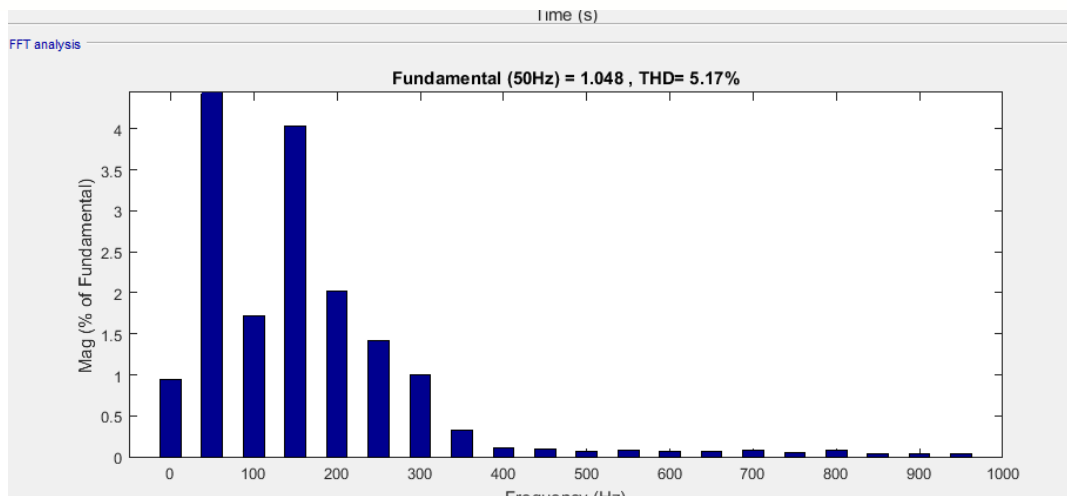

Fig. 6 THD analysis of bus voltage for harmonic reduction with UPFC

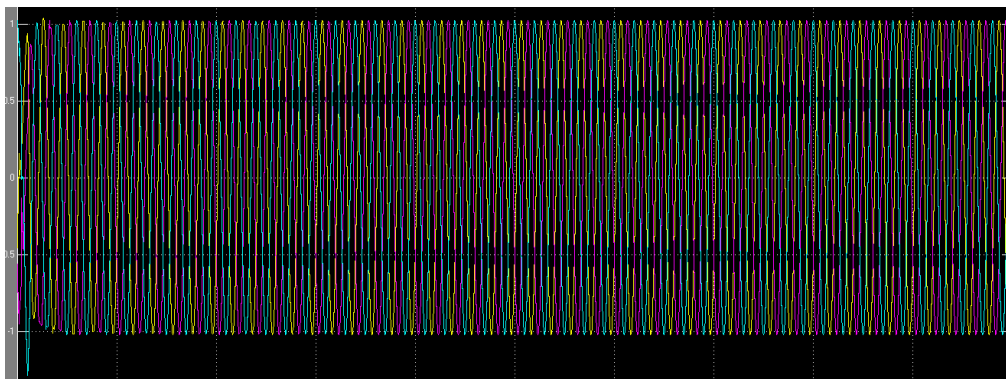

Fig. 7 Harmonics reduction in bus voltage with DPFC

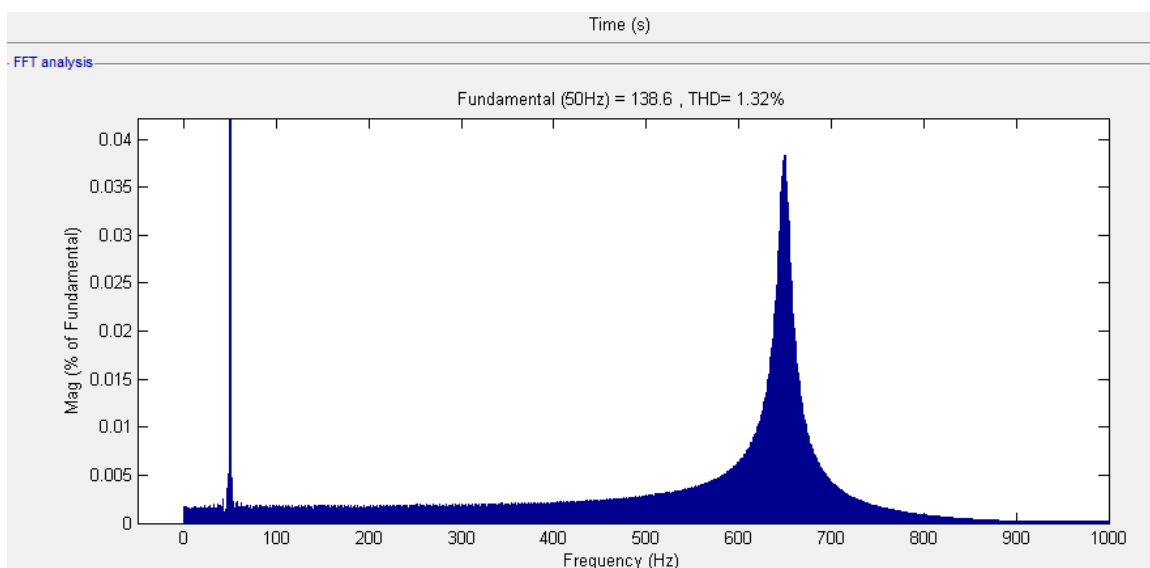

Fig. 8 THD analysis of bus voltage for harmonic reduction with DPFC

## **V. CONCLUSION**

In this paper represent the comparative analysis of UPFC and DPFC for the reduction of the harmonic by FACTS- devices. From the simulation results, it is showed that there is reduction in the THD with DPFC compare to the UPFC. Fast harmonics reduction with DPFC and also mitigate the bus voltage of the power system.

## **REFERENCES**

- [1.] Arup Ratan Bhowmik<sup>1</sup>, Champa Nandi<sup>2</sup>, “Implementation of Unified Power Flow Controller (UPFC) For Power Quality Improvement in IEEE 14-Bus System”, Int. J. Comp. Tech. Appl., Vol 2 (6), 1889-1896.
- [2.] Hakim Elahi Tooraji and Nekoubin Abdolamir, “Improving Power Quality Parameters in AC Transmission Systems Using Unified Power Flow Controller”, Research Journal of Recent Sciences, ISSN 2277-2502, Vol.2 (4), 84-90, April (2013).
- [3.] Juan Segundo-Ramirez and A. Medina, “Analysis of Power Electronic Controllers in Electric Power Systems Using Simulink”, Technology and Engineering Applications of Simulink.
- [4.] Zhihui Yuan, Sjoerd W. H. de Haan, Jan Braham Ferreira and Dalibor Cvoric, “A FACTS Device: Distributed Power-Flow Controller (DPFC)”, IEEE Transactions on Power Electronics, Volume.25, No.10, October 2010.
- [5.] Akhib Khan Bahamani, Dr. G.V. Siva Krishna Rao, Dr. A.A. Powly Thomas and Dr V.C. VeeraReddy, “Modelling and Digital Simulation of DPFC System using Mat lab Simulink”, International Journal of Emerging Trends in Electrical and Electronics, Volume.6, August 2013.
- [6.] K.Venkata Nagaraju and N.C. Kotaiah, “Modelling and Analysis of Distributed Power Flow controller Based On Reliability of the Transmission System”, International Journal of Electrical, Electronics and Data Communication, Volume 1, October 2013.
- [7.] D.Radhika and Dr. B.V.Sanker Ram, “Improvement of Voltage Profile of a Transmission System Using D – FACTS”, IOSR Journal of Electrical and Electronics Engineering, Volume 10, April 2015.