

Design of Human Powered Forklift

Rahul Toraskar¹, Onkar Vangutte², Onkar Patil³

Department of Mechanical Engineering Bharati Vidyapeeth's College Of Engineering Kolhapur.

Shivaji University, kolhapur.

ABSTRACT

Many industries used forklifts for lifting heavy goods etc. These are applicable for large scale industries and highly automated industries. Since the small scale industries requires repeated movement of load from one station to another the use of these forklift will not be economical, hence we decided to design of forklift which helps small scale industries in transporting the load in easy and cost efficient way.

The idea was to lift and shift the material on shop floor where very low frequency of shifting is required and the object being heavy enough for humans to shift the material. Where the lifting could be done by rope and pulleys provided in approachable place near to foot pedal. And once the load is lifted by the fork the vehicle could be propelled with the operator itself by his pedal effort just like bicycle. The vehicle could be stressed easily without any problem in the job floor as well meant for flat floor.

I. INTRODUCTION

Now a days due to heavy work load environment in the mechanical industrial lines workers are been depressed for carrying a heavy load, where the workers are prone to unhealthy conditions. Due to these factors some load carrying machines were developed in the recent past years.

Working in the mechanical workshops or any other large fabrication unit, where load is to carry (bars, plates, machined jobs etc.) from one unit of the factory to the other unit this device is useful. The **In-plant goods carrier system** is user friendly as designed. The device finds greater use in the industrial lines for transport of the machined jobs, carrying goods internally in the fabrication plant.

The present In-plant goods carrier system is used for the industrial applications which can be moved from one place to other and hence the work such as carrying goods or any other is done within the time schedule and the particular cycle time for that operation is saved, the handling, fixing and the other time wasted in carrying goods can be better utilized to carry out the production.

The device works on the simple mechanism of the motion transmission. It consists of bevel gear mechanism where motion from wheel is transmitted to rear wheels with the help of chain and the device moves further.

There is paddle attached to the front wheel axle to rotate and turn. The device can be used on any surface of ground as the wheels are made up of mild steel which is hardened to carry the entire load.

1.1 SCOPE

We feel the project that we have done has a good future scope in any engineering industry. The main constraint of this device is the high initial cost but has low operating costs. The machine designed should be based on the size.

Savings resulting from the use of this device will make it pay for itself with in short period of time & it can be a great companion in any engineering industry dealing with goods transport. One can properly design to take larger loads than 0.5 ton.

The device affords plenty of scope for modifications, further improvements & operational efficiency, which should make it commercially available & attractive. If taken up for commercial production and marketed properly, we are sure it will be accepted in the industry. It has plenty of scope if the device is made larger in size so that the capacity of carrying weight & the load is maintained properly. Distance between two arms of the fork can be adjusted using normal lead screw arrangement.

1.2 OBJECTIVE

- ❖ To make a device which is suitable economically for small Scale industries: taking in to consideration the cost factor this device is suitable for small scale as well as big scale industries.
- ❖ Taking safety as prime consideration: This device is safer in all respects.
- ❖ To build a device which is helpful for carrying in plant loads
- ❖ To develop a device which is helpful for the industrial works etc.
- ❖ To save the cycle & other time of the job production.

II. METHODOLOGY

$$F=M*A$$

Mass of forklift vehicle with driver = 100 kg

Acceleration assumed as = 1G

$$F= 100*9.81$$

$$= 981$$

$$F(\text{normal}) = 981/2$$

$$= 490.5$$

$$F \text{ (frictional)} = 0.75 * 490.5$$

$$= 367.87$$

Now, Torque required to move forklift vehicle

$$T = F * \text{Radius of wheel}$$

$$= 367.87 * 127$$

$$= 46719.49 \text{ N-mm}$$

$$= 46.71 \text{ Nm}$$

By hand human can apply force 10 KG

$$F = 10 * 9.81 \text{ N}$$

$$\text{Torque} = \text{force} * \text{pedal arm length}$$

$$46.71 = 98.1 * \text{pedal arm length}$$

$$\text{Pedal arm length} = 0.476 \text{ m}$$

We know total torque required to move vehicle = 46.71 Nm

As speed of vehicle is very less so neglect dynamic weight distribution

$$\text{Total weight of forklift vehicle} = 100$$

Total weight will be divided into two axles of forklift vehicle

$$\text{Front axle} = 50 \text{ Kg}$$

$$\text{Rear axle} = 50 \text{ Kg}$$

Torque required to move front axle

$$T = F * \text{Radius of wheel}$$

$$F = 50 * 9.81$$

$$= 490.5 \text{ N}$$

$$F(\text{normal}) = 490.5/2$$

$$= 245.2$$

$$F(\text{frictional}) = 183.93 \text{ N}$$

$$T = 183.93 * (25.4 * 5)$$

$$= 23.35 \text{ Nm}$$

$$\text{Speed ratio} = T_2/T_1$$

$$= 46.71/23.35$$

$$= 2$$

$$\text{Number of teeth on driving sprocket} / \text{Number of teeth on driven sprocket} = 2$$

As pedal arm length is 476 mm

Sprockets of 200 mm dia. will enough to distribute all torque.

Hence standard sprocket having dia. 180 mm and 40 numbers of teeth

From driving sprocket specifications and speed ratio

Driven sprocket diameter = 90 mm and number of teeth = 20

III. CONSTRUCTION

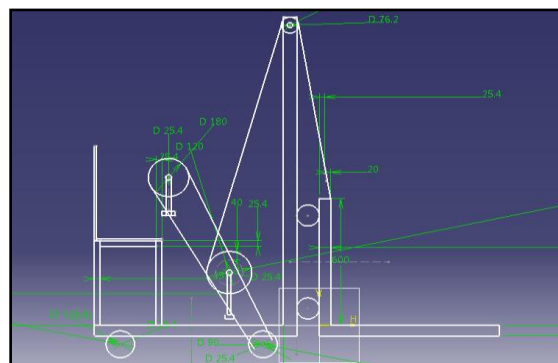

- A) FRONT WHEEL - Front wheels are used for forward and backward movement and it also rotate in angle for turning of machine.
- B) REAR WHEEL - Rear wheels move only in forward and reverse direction.
- C) FORK FRAME- Fork frame is made of mild steel. Fork works as lifting member.
- D) BEARING- Bearing are mounted in between the body member and fork frame.
- E) SPROCKET- Sprocket has 44 teeth, which transmit motion and power. Two sprocket are attached to two front wheel and two sprocket attached to handle.
- F) CHAIN - Bicycle chains are used. Chains are used to transmit power from handle to front wheels for moving the machine.
- G) PULLEY - Pulley is mounted at top of body frame. It is used to support the wire.
- H) PADDLE- It is used for lifting the weight, paddle are also used as handle for transmitting motion.

IV. ANALYSYS REPORT

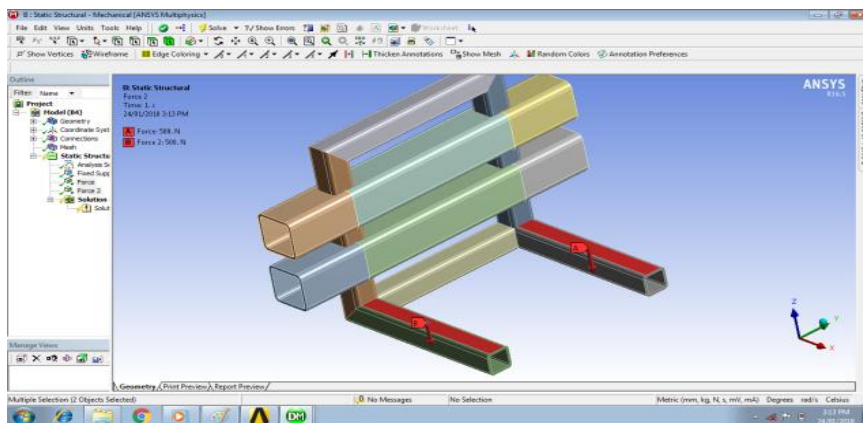

fig. fork loads loads

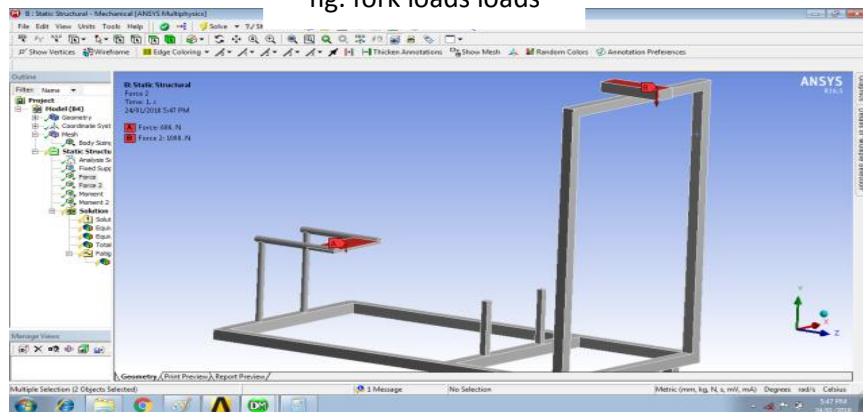

fig. fork lift forces

V. CONCLUSION

We conclude that, this project will helpful for small scale industrialists as it is easy to operate with less cost and indirectly it will save the labour cost. savings resulting from the use of this machine will make it pay for itself with in short period of time & it can be a great companion in any field dealing with rusted and unused metals.

VI. ACKNOWLEDGMENT

We would like to thank Prof. Jarag S. P. For his guidance. His enthusiasm and patience, as well as his technical expertise, were essential in helping us overcome many obstacles. Without him this dissertation would not have been possible.

REFERENCE

- [1] R.P.Kumar Rompicharla – PG Student, Dr. K. Rambabu – Associate Professor, “Design And Analysis Of Drive Shaft With Composite Materials” Affiliated to Andhra University, Research Expo International Multidisciplinary Research Journal Volume - II, Issue - II June - 2012 ISSN: 2250 -1630.
- [2] ISO. ISO Standard 2328:2007, Fork-lift trucks – Hookon type fork arms and fork arm carriages – Mounting dimensions. ISO, second edition, 2007.
- [3] “Forklift Stability and Other Technical Safety Issues” Accident Research Centre Monash University Victoria 3800 Australia (Authors: J Lambert & Associates) an initiative funded by Work Safe, Victoria. April 2003
- [4] Rangaswamy, T.; Vijayrangan, S. (2005). “Optimal sizing and stacking sequence of composite drive shafts”. *Materials science, Vol. 11 No 2*.India.
- [5] Amboji Sudhakar R.1, Humane Yogesh A.2,Chavan Rohan R.3,Patil Jyotsna C.4,Kshirsagar Prashant R.5 “Design and Fabrication of Three Way Tipper Mechanism”. *International Journal of Research in Advent Technology, Vol.2, No.4, pp. 261-265, Vol.2, No.4, April 2014. April 2014E-ISSN: 2321-9637.*